

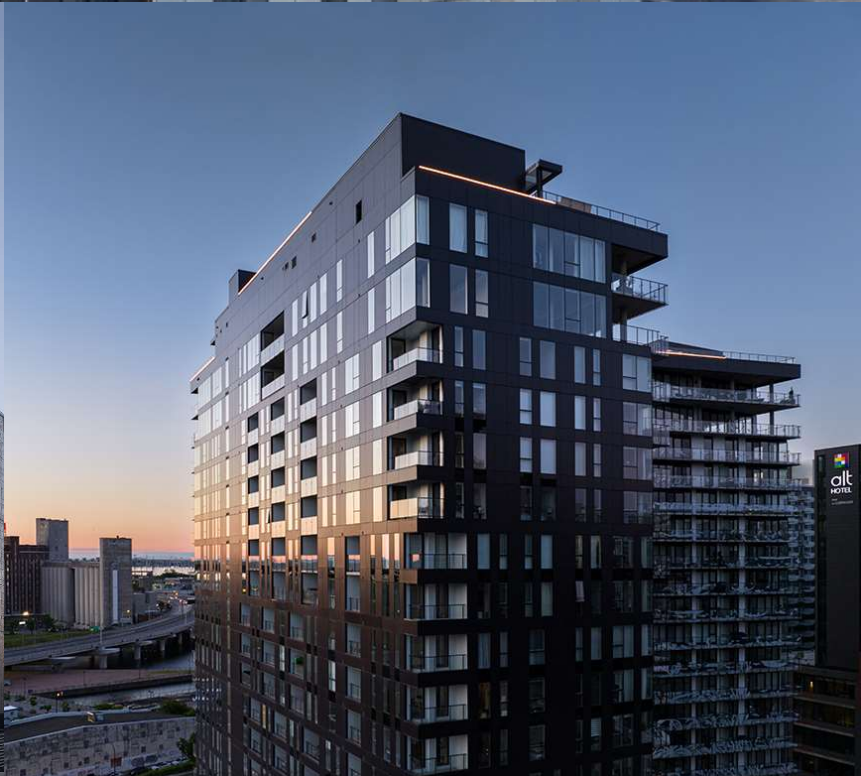

STEKAR





[Table of contents](#)

Sectional view

SM160 window vs opaque glass panels.....	page 4
SM160 window vs opaque glass panel next to wall foundation.....	page 5
Opaque glass panel vs opaque glass panel next to wall foundation.....	page 6
SM160 window vs SM160 window.....	page 7
Operable SM160 window vs opaque glass panel.....	page 8
Operable SM160 window vs SM160 windows.....	page 9
Compartmentalization between opaque glass panels and SM160 window.....	page 10
Laminated glass soffits.....	page 11
Facade glass panels vs laminated glass soffit.....	page 12
Laminated glass soffit vs facade glass panels.....	page 13
Opaque glass panel vs SM160 window in front of concrete slab.....	page 14
Opaque glass panel vs parapet – Options #1 & 2.....	page 15
Opaque glass panel vs parapet – Option #3.....	page 16
Offset opaque glass panels.....	page 17
Opaque glass panel vs Stekar aluminum panel.....	page 18
Opaque glass panel vs aluminum panel by others.....	page 19
Opaque glass panels vs brick.....	page 20
Opaque glass panels vs curtain wall.....	page 21
Opaque glass panels vs triple glass curtain wall.....	page 22
Opaque glass panels vs typical window.....	page 23
SM160 window vs opaque glass panels on steel structure.....	page 24



[Table of contents \(...\)](#)

Plan view

Opaque glass panel vs opaque glass panel.....	page 25
Opaque glass panel vs opaque glass panel ; 90° corner.....	page 26
Opaque glass panel vs opaque glass panel ; < 90° corner.....	page 27
Opaque glass panel vs opaque glass panel ; > 90° corner.....	page 28
Opaque glass panel vs opaque glass panel ; interior 90° corner	page 29
Opaque glass panel vs bricks.....	page 30
Opaque glass panel vs bricks ; interior 90° corner.....	page 31
Opaque glass panel vs bricks ; exterior 90° corner.....	page 32
Opaque glass panel vs Stekar aluminum panel.....	page 33
Offset opaque glass panels.....	page 34
Opaque glass panel vs SM160 windows.....	page 35
Opaque glass panel between SM160 windows.....	page 36
SM160 windows ; exterior 90° corner.....	page 37
SM160 window vs opaque glass panel ; 90° corner.....	page 38
Opaque glass panel vs curtain wall.....	page 39
Opaque glass panel vs triple glass curtain wall.....	page 40



STEKAR

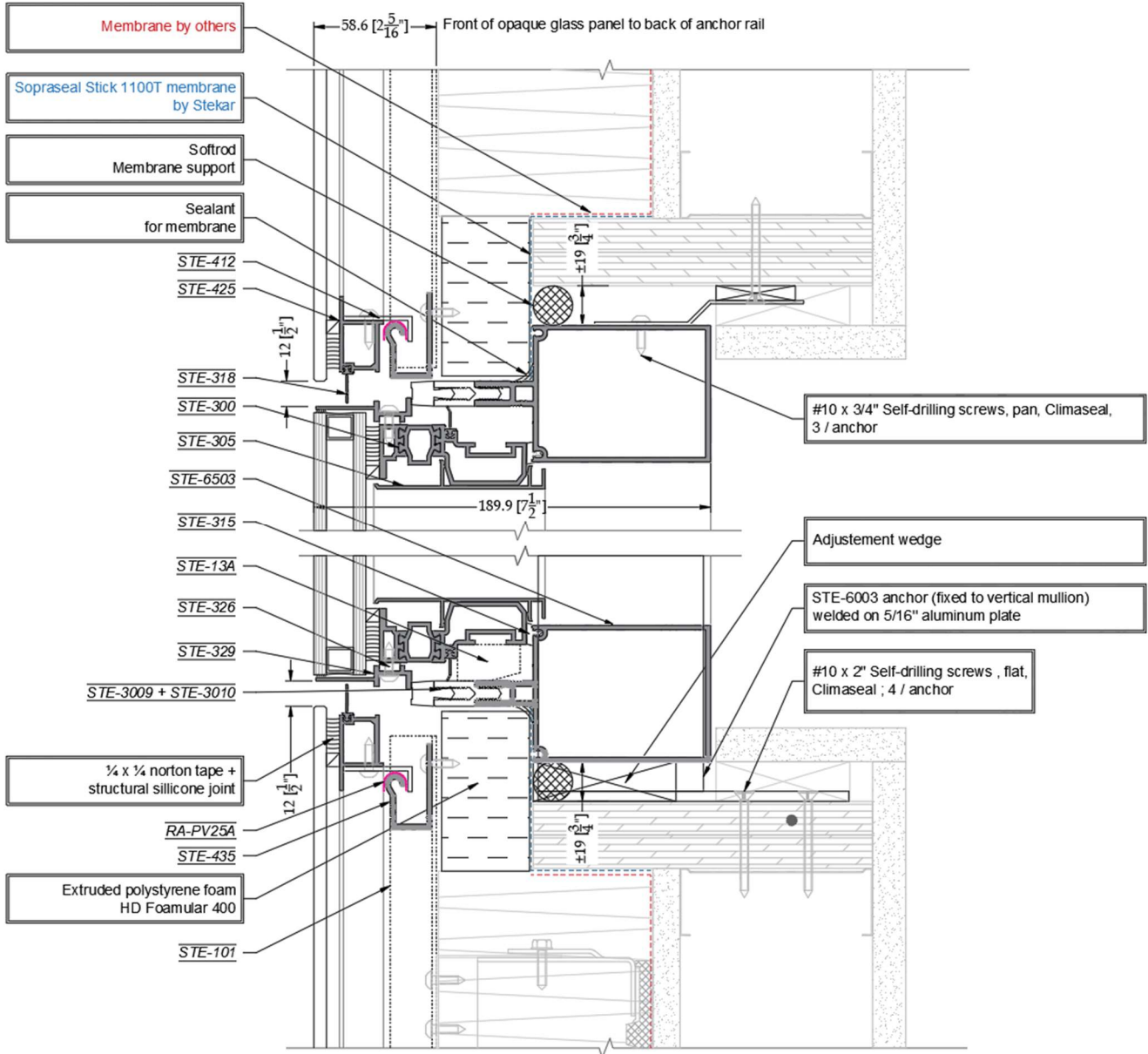

Sectional view

SM160 window vs opaque glass panels



STEKAR

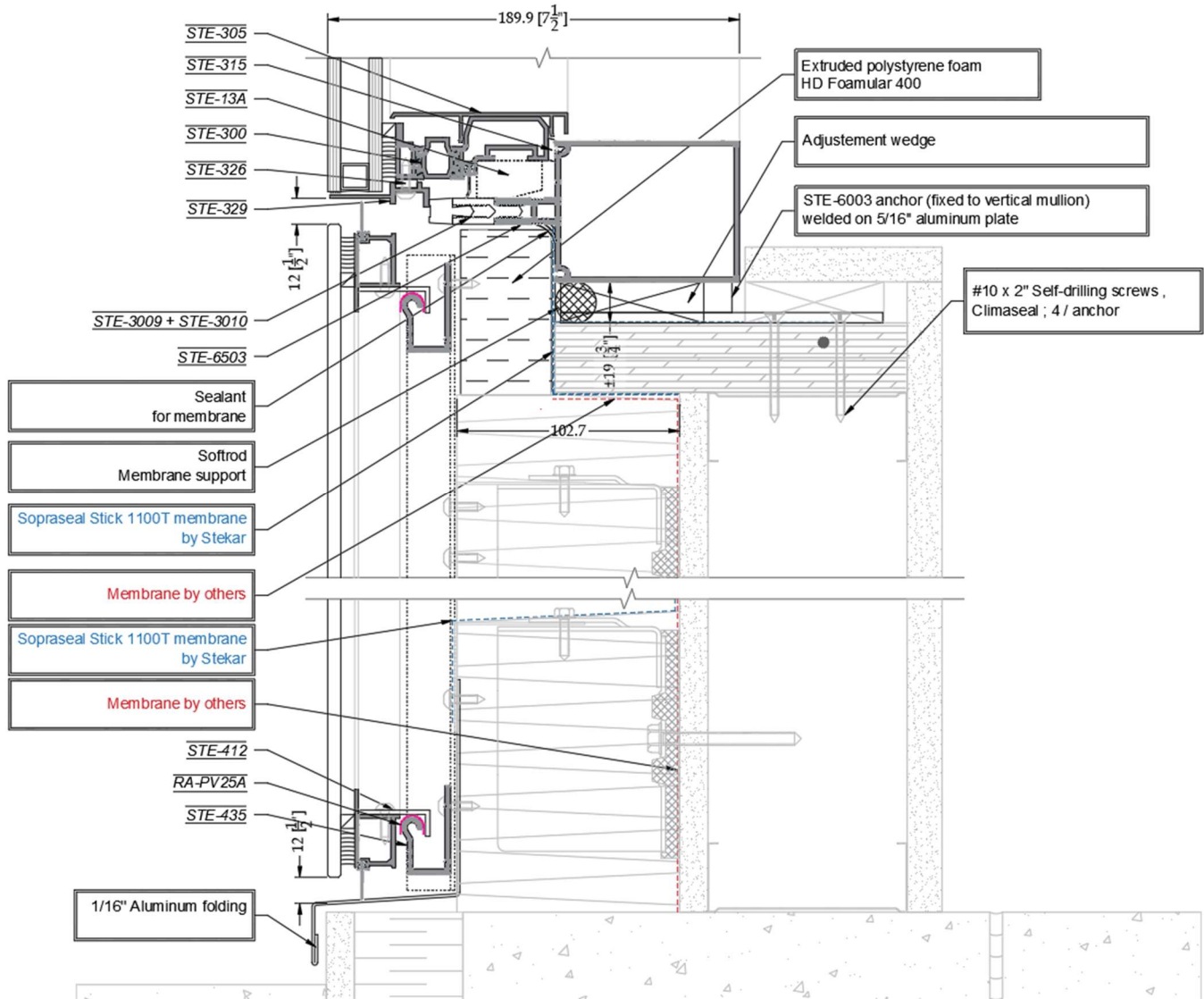



STEKAR

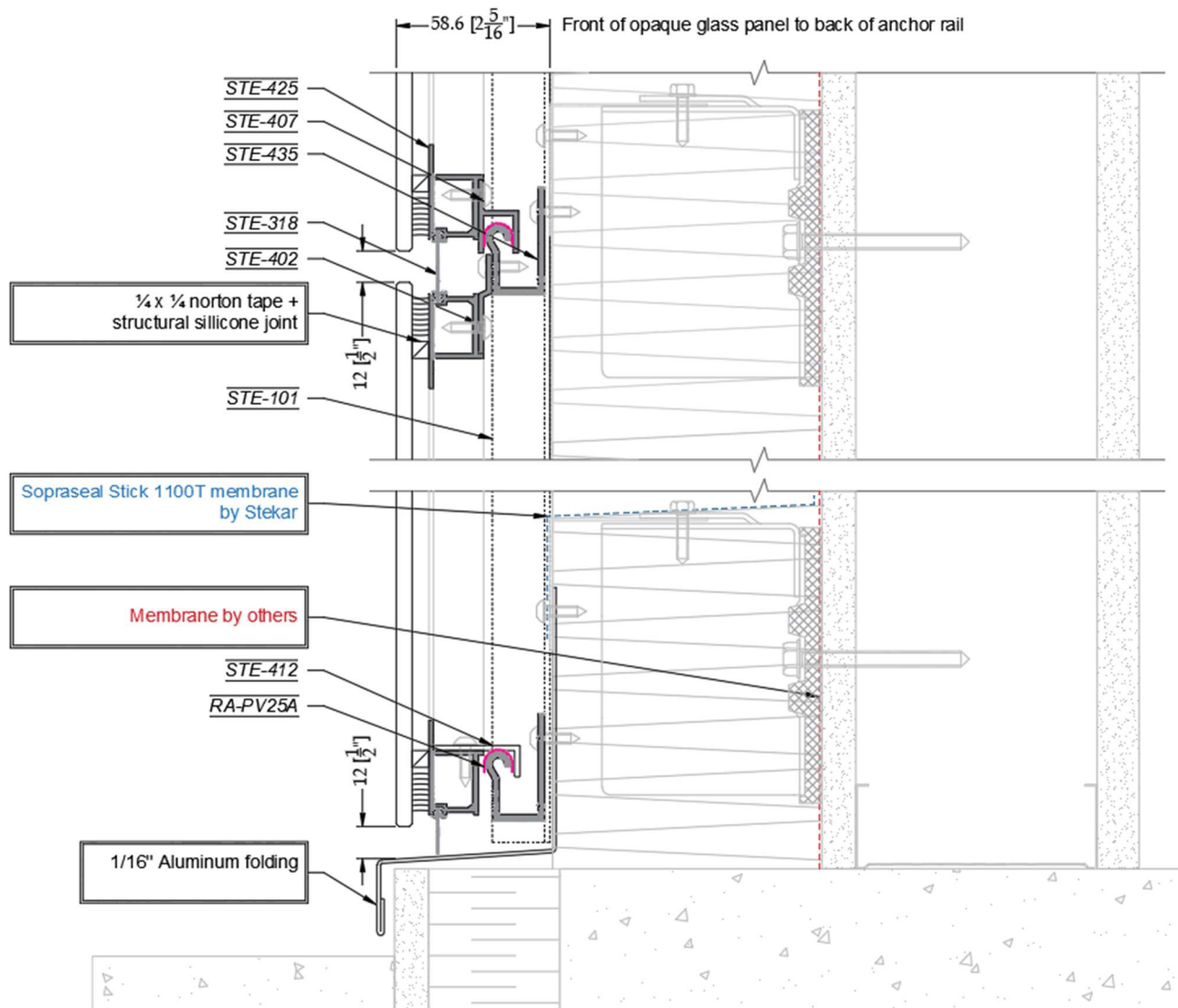



STEKAR

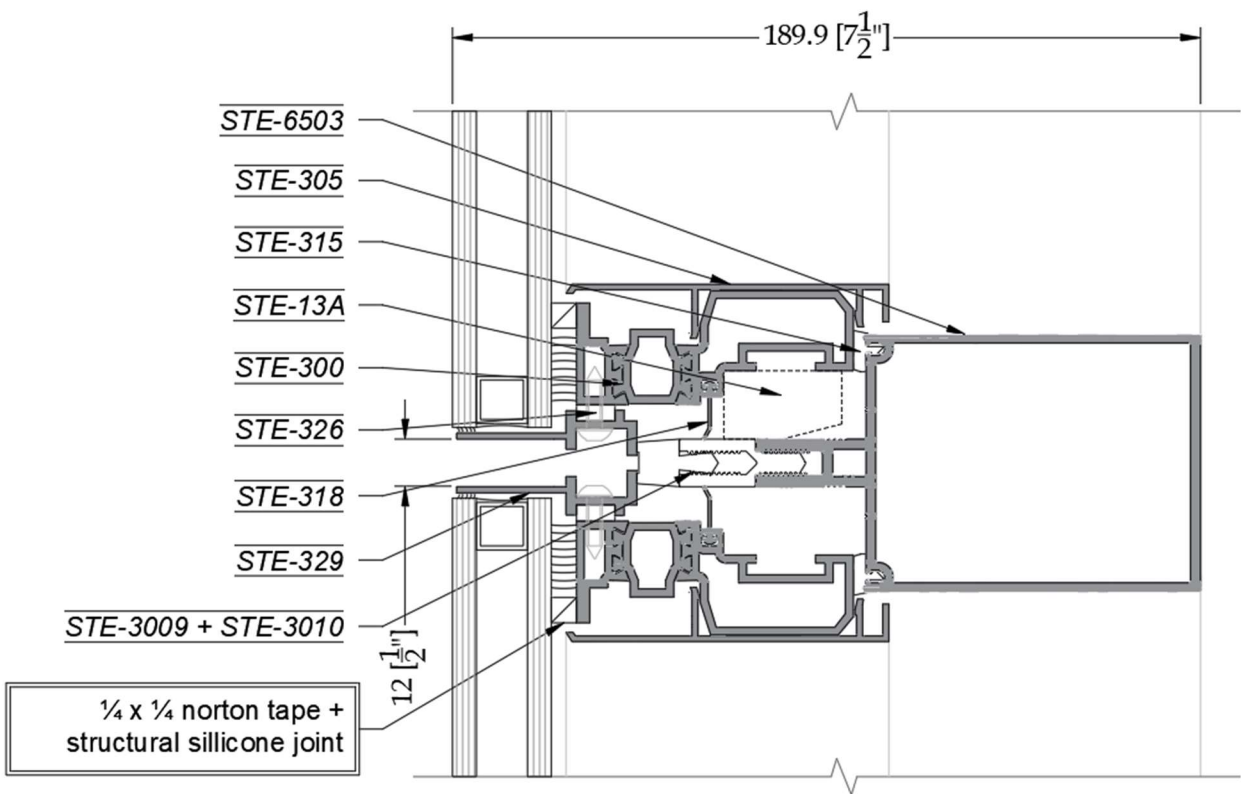

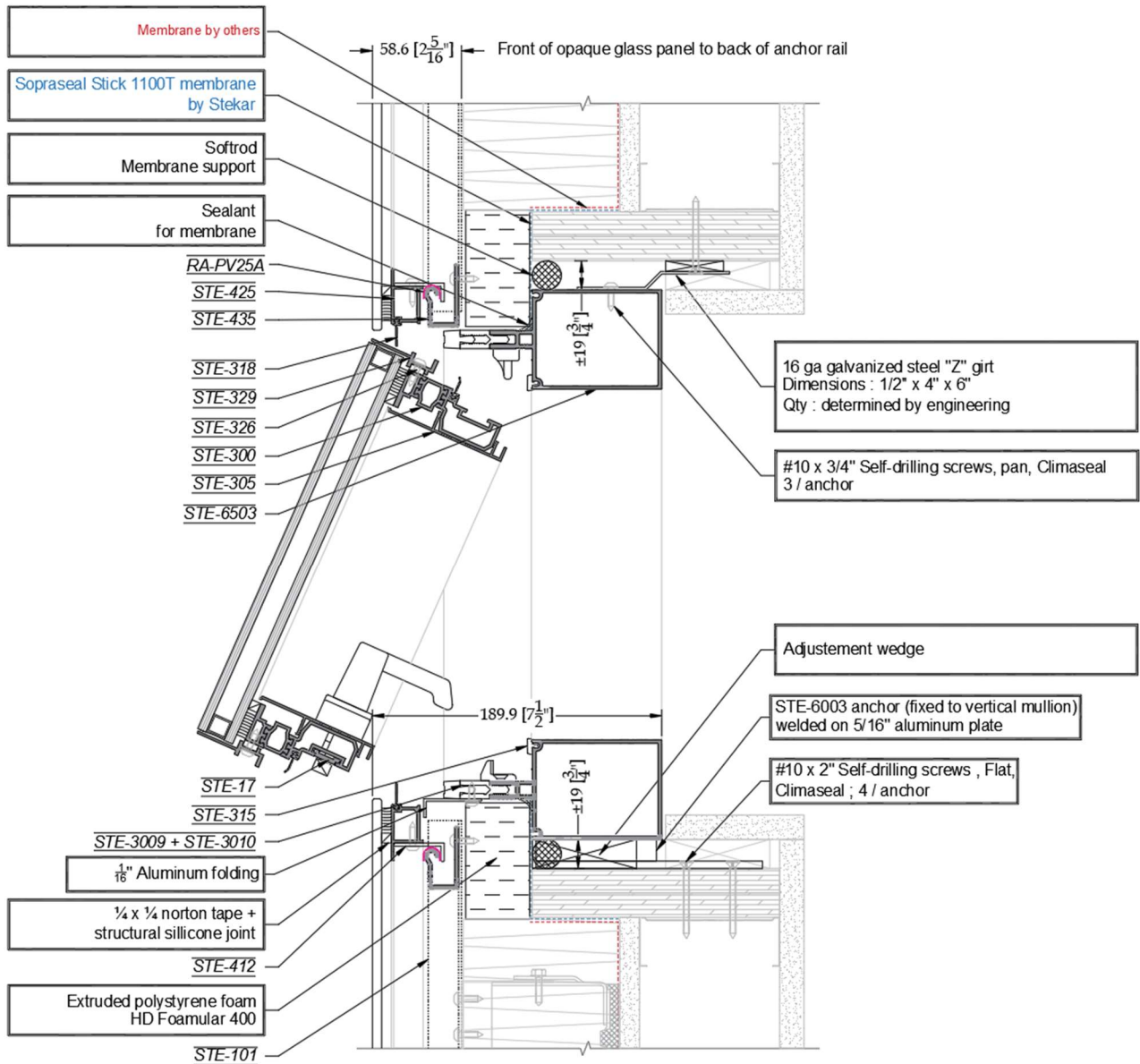

* For more information about hardware, see technical datasheet.



STEKAR

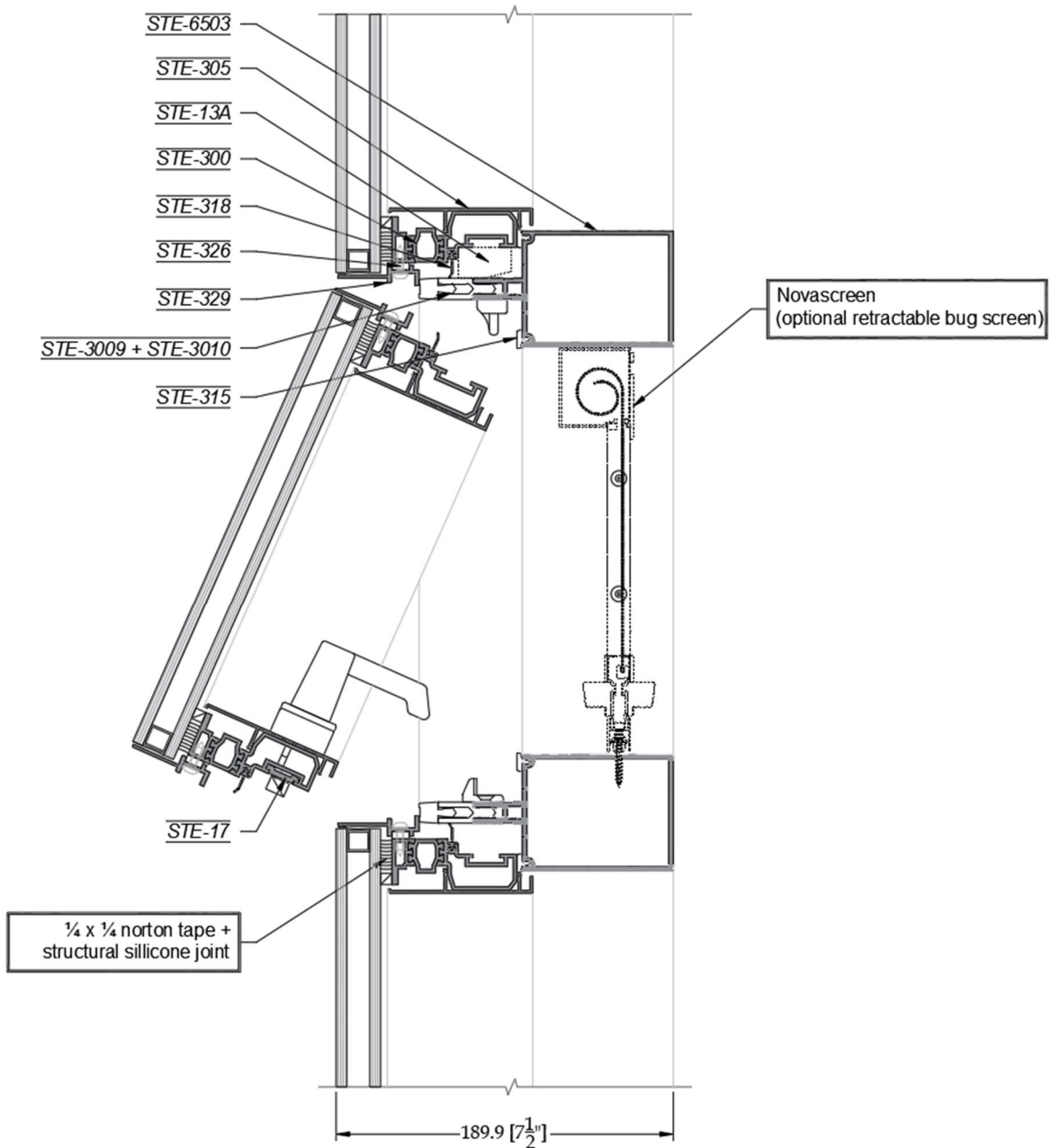

* For more information about hardware, see technical datasheet.



STEKAR

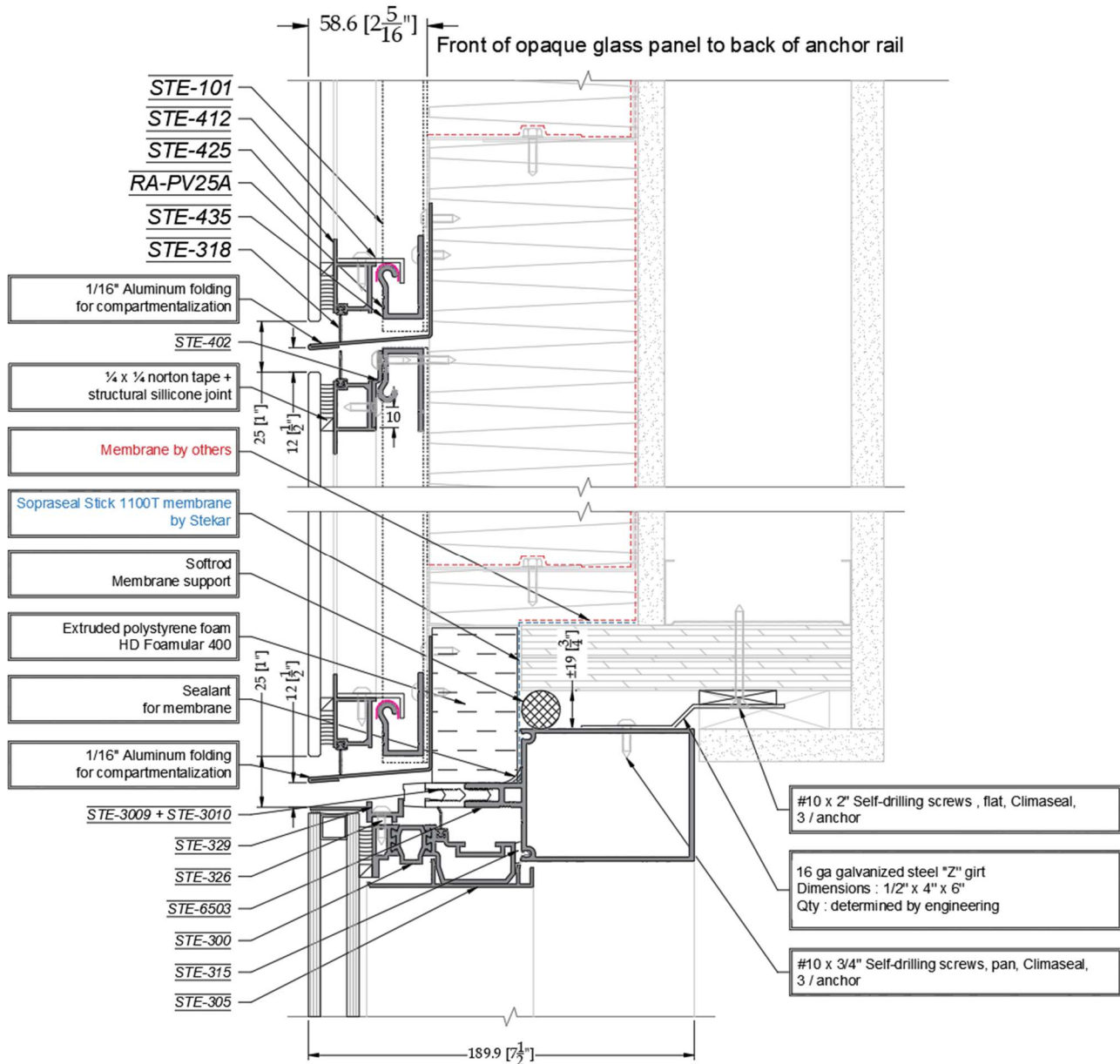

* For more info regarding compartmentalization, see technical datasheet.



STEKAR

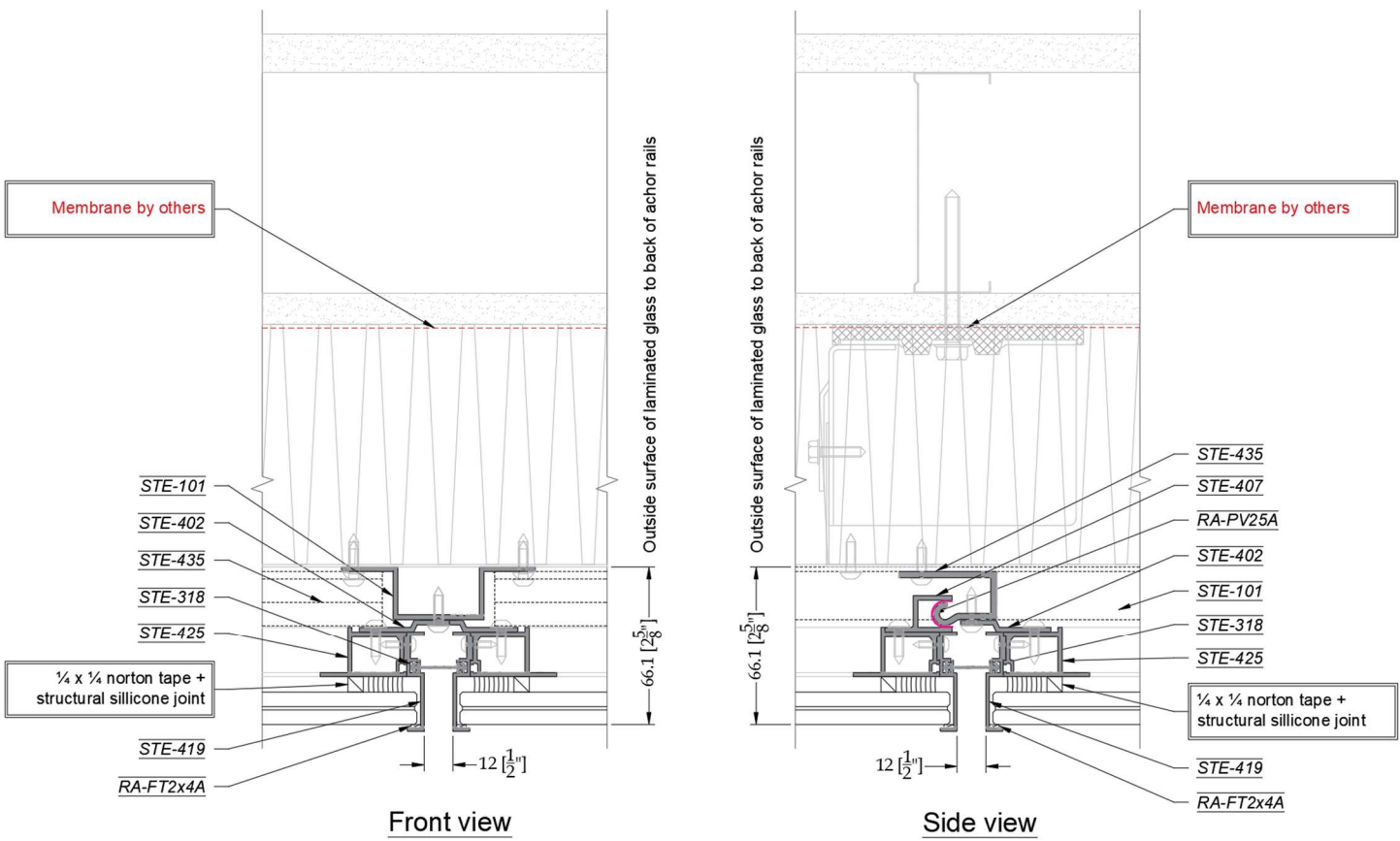



STEKAR

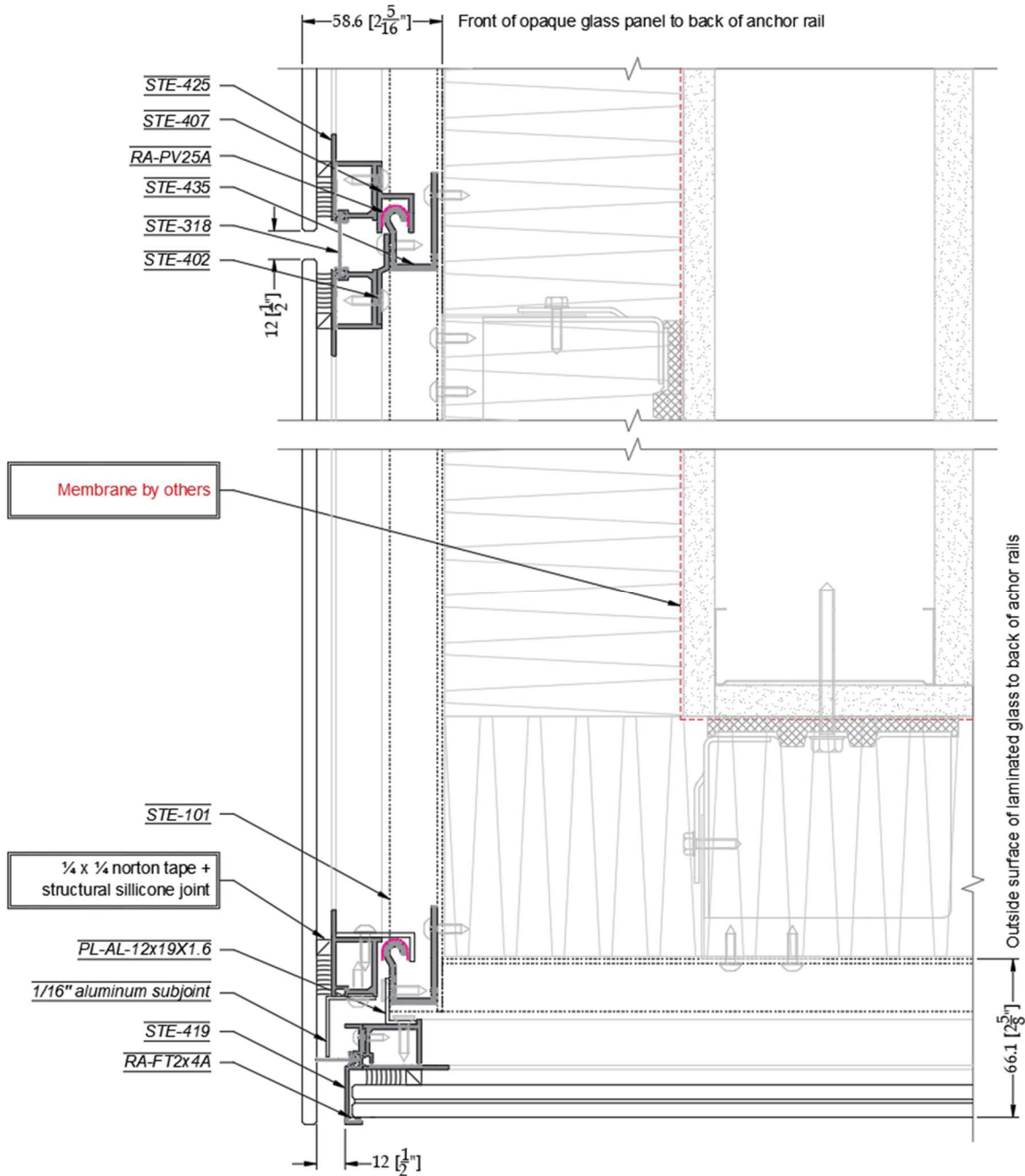

Sectional view

Facade glass panels vs laminated glass soffit



STEKAR

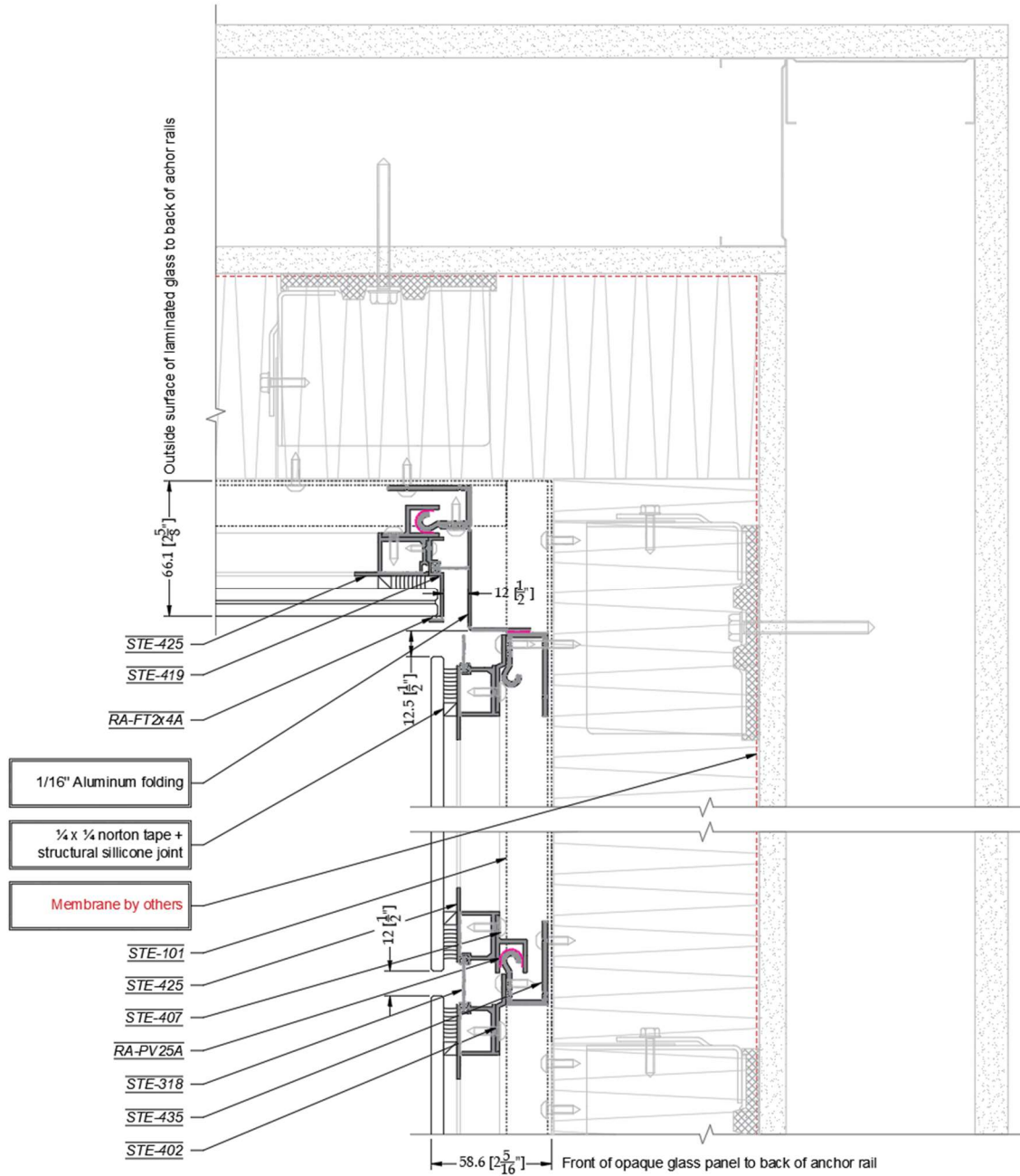

Sectional view

Laminated glass soffit vs facade glass panels



STEKAR

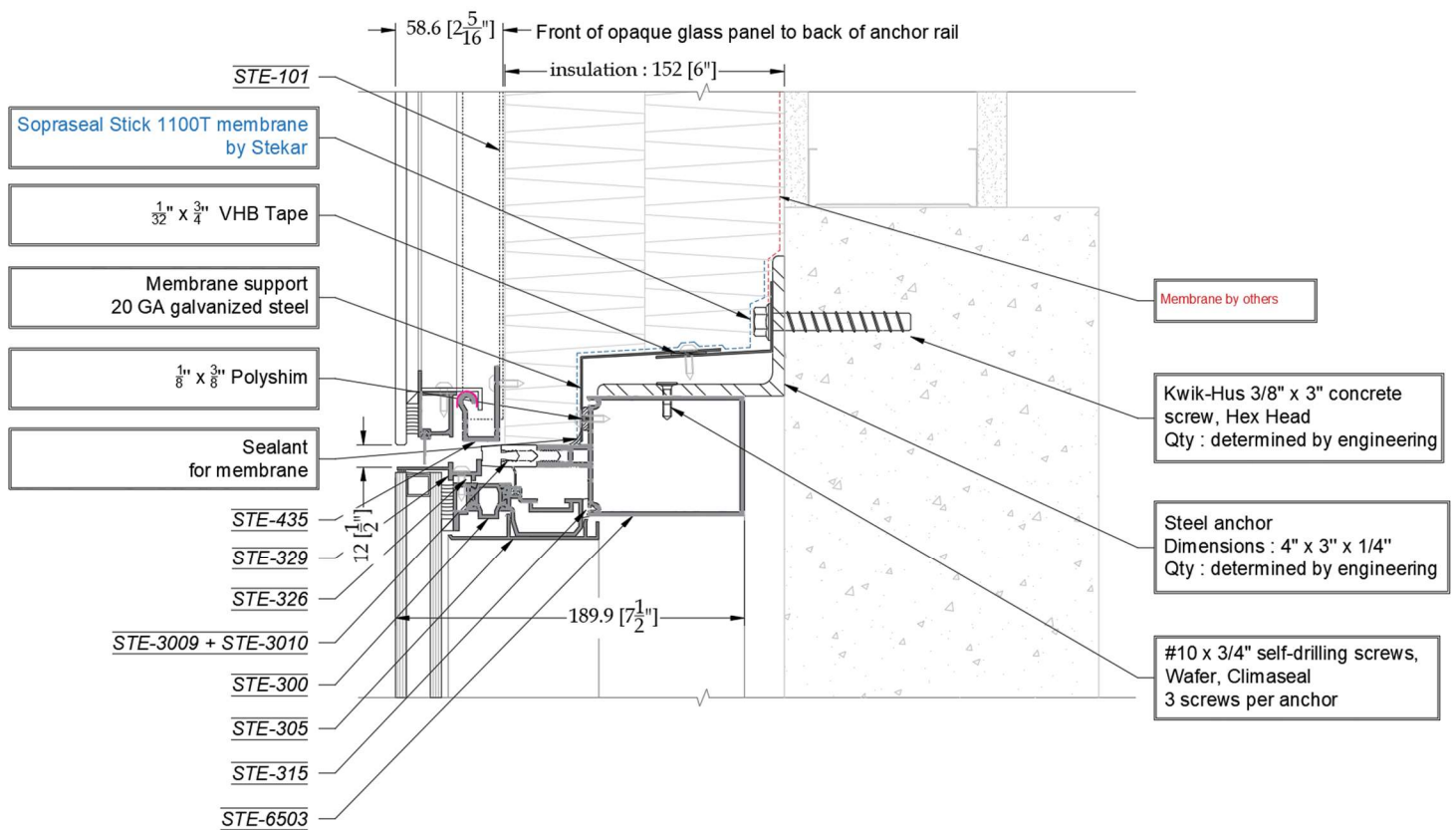



STEKAR

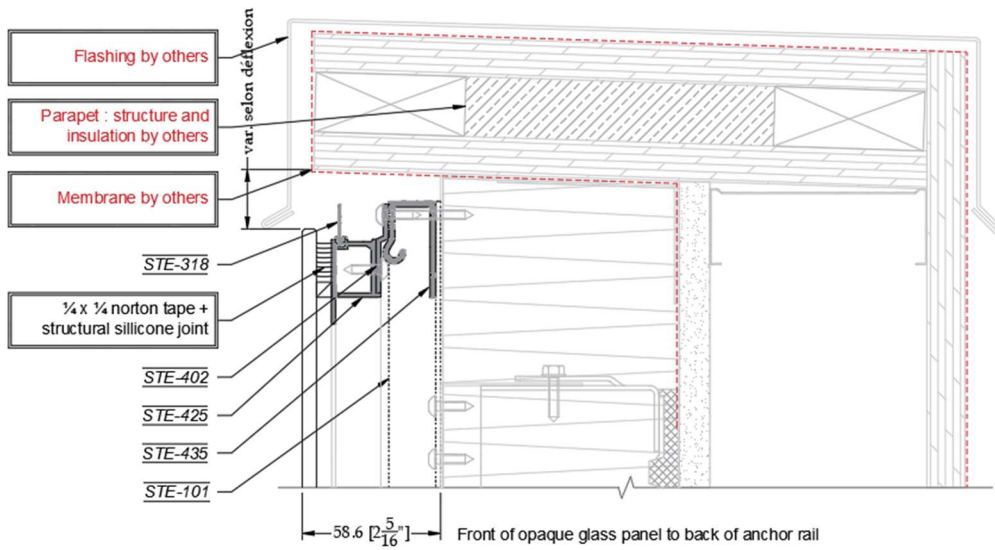

Option #1

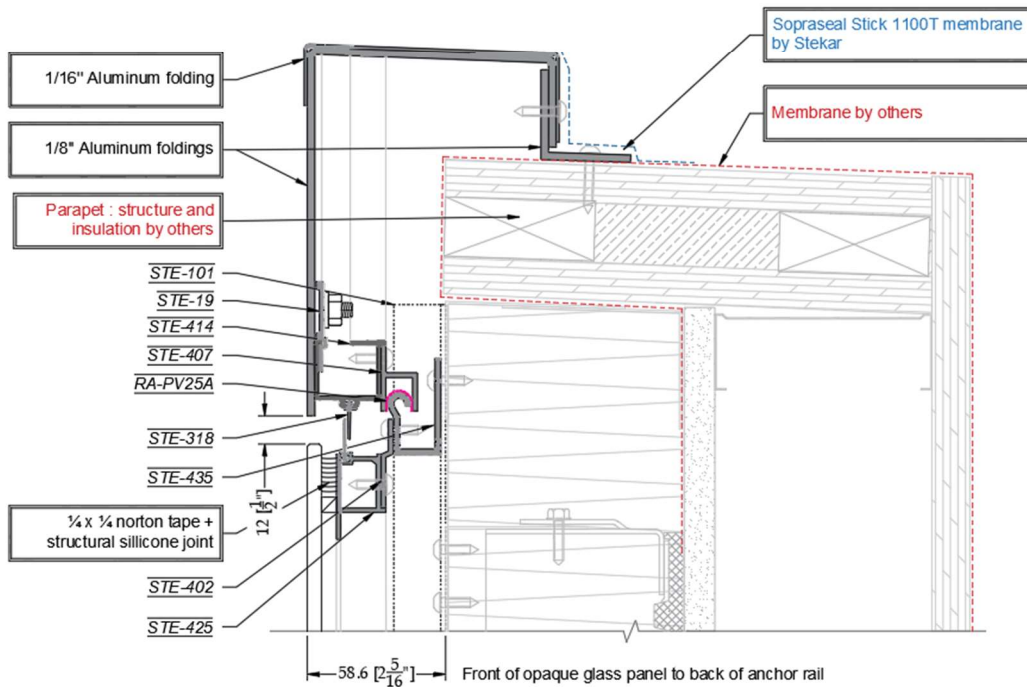

Option #2

This configuration is adequate with a minimum parapet deflection.

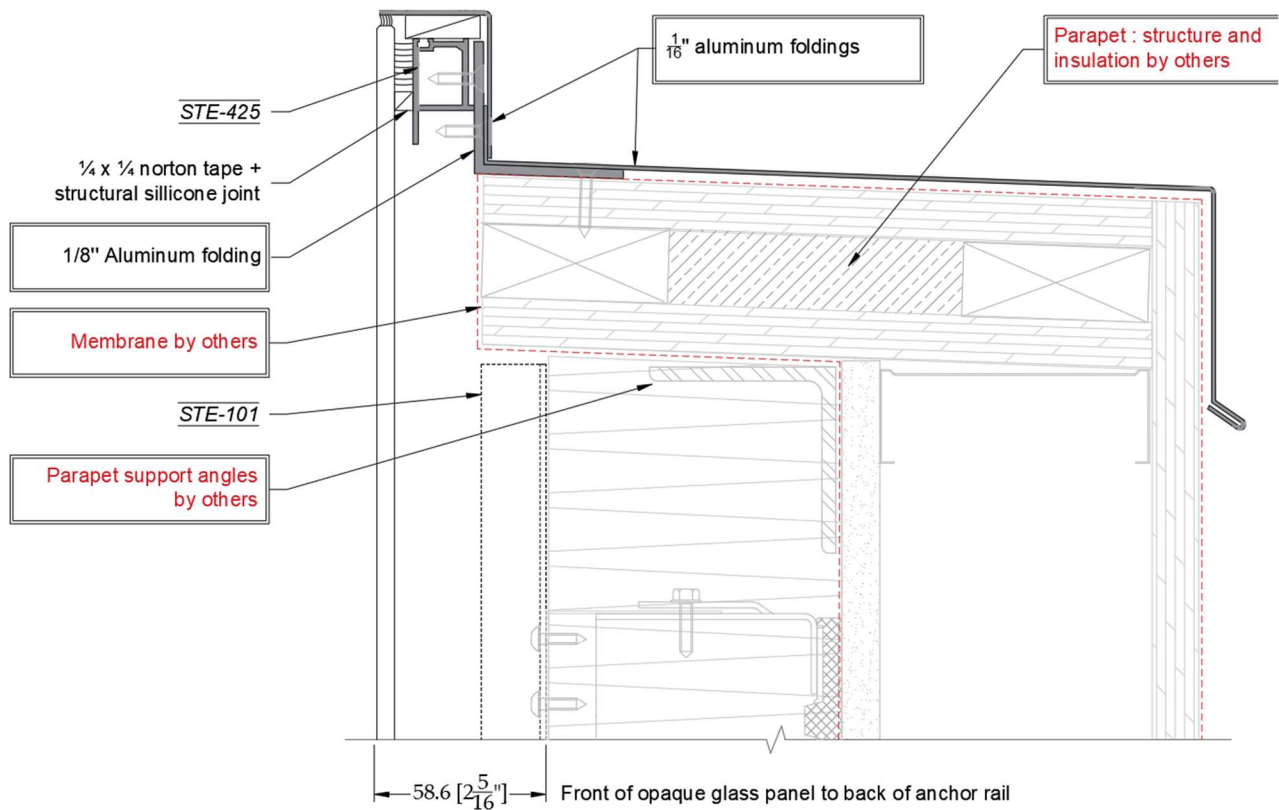

Option #3



STEKAR

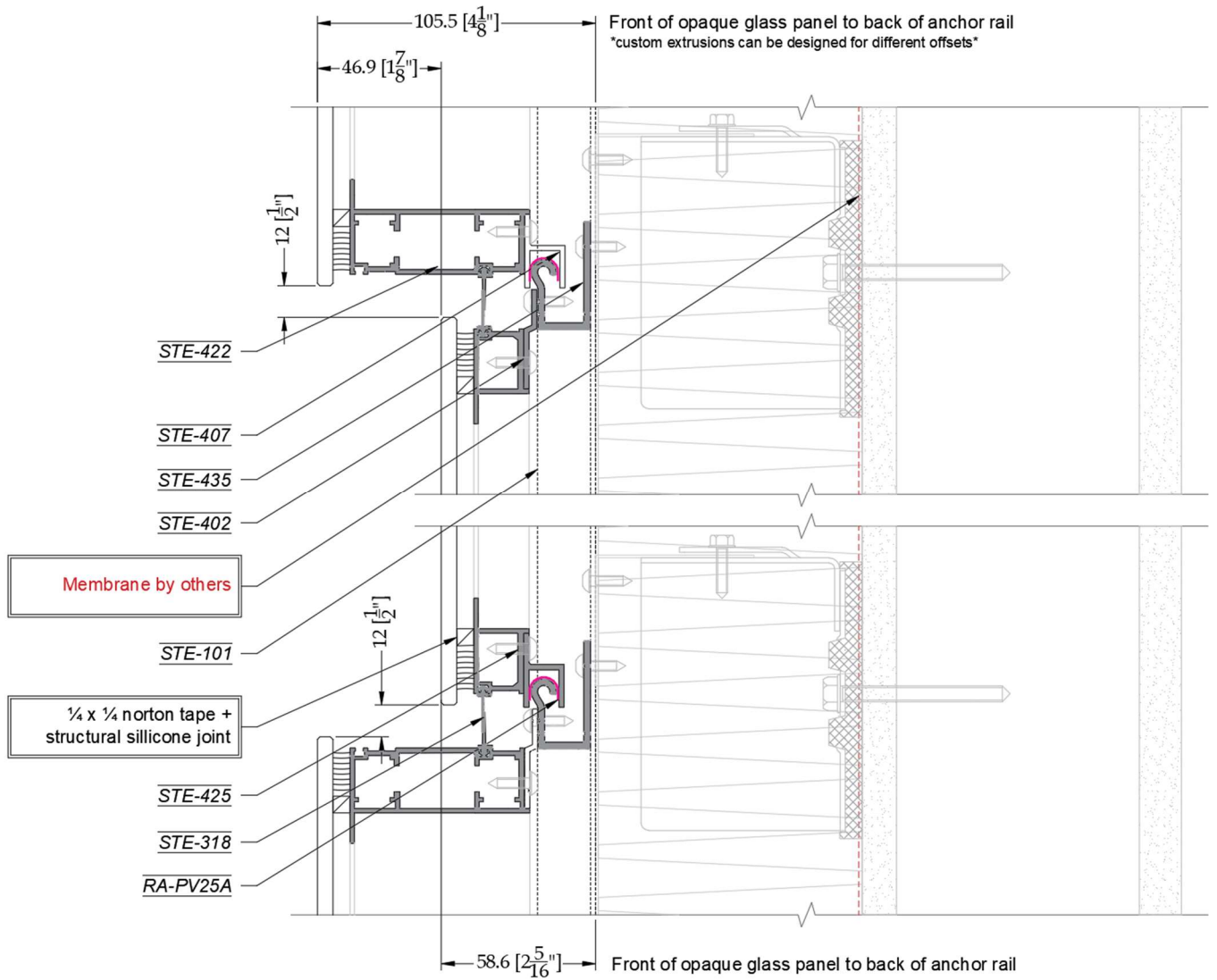



STEKAR

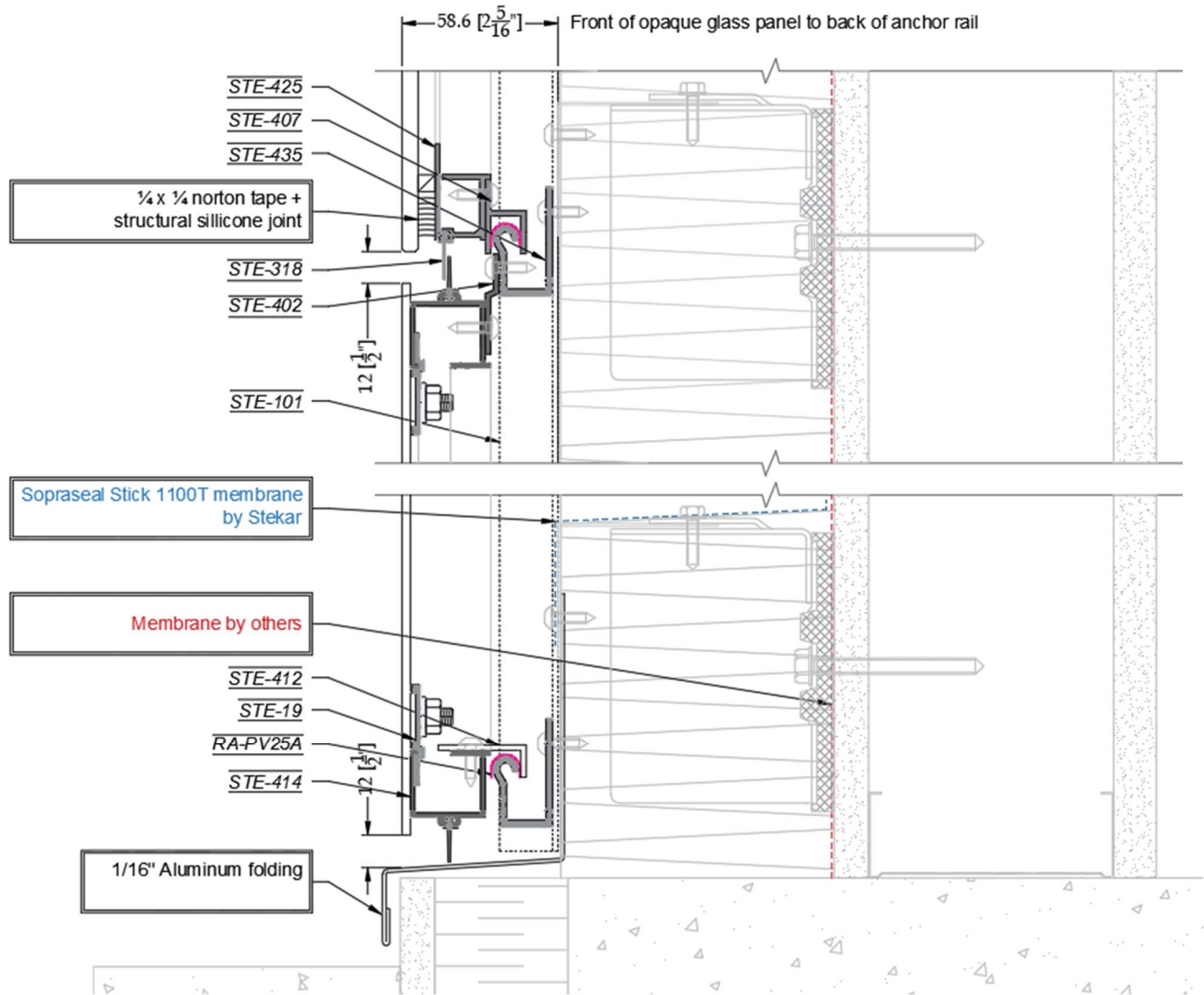



STEKAR

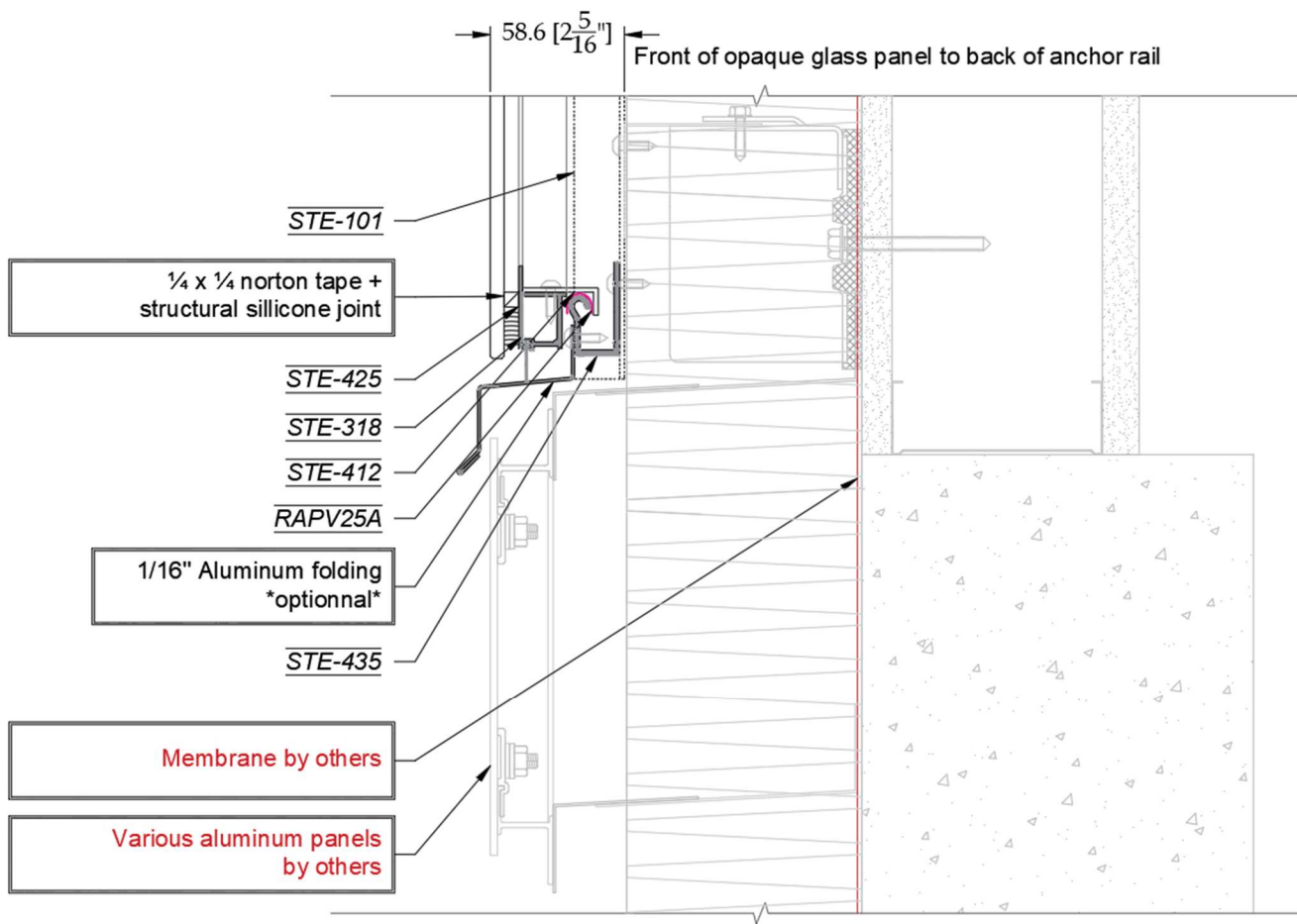



STEKAR

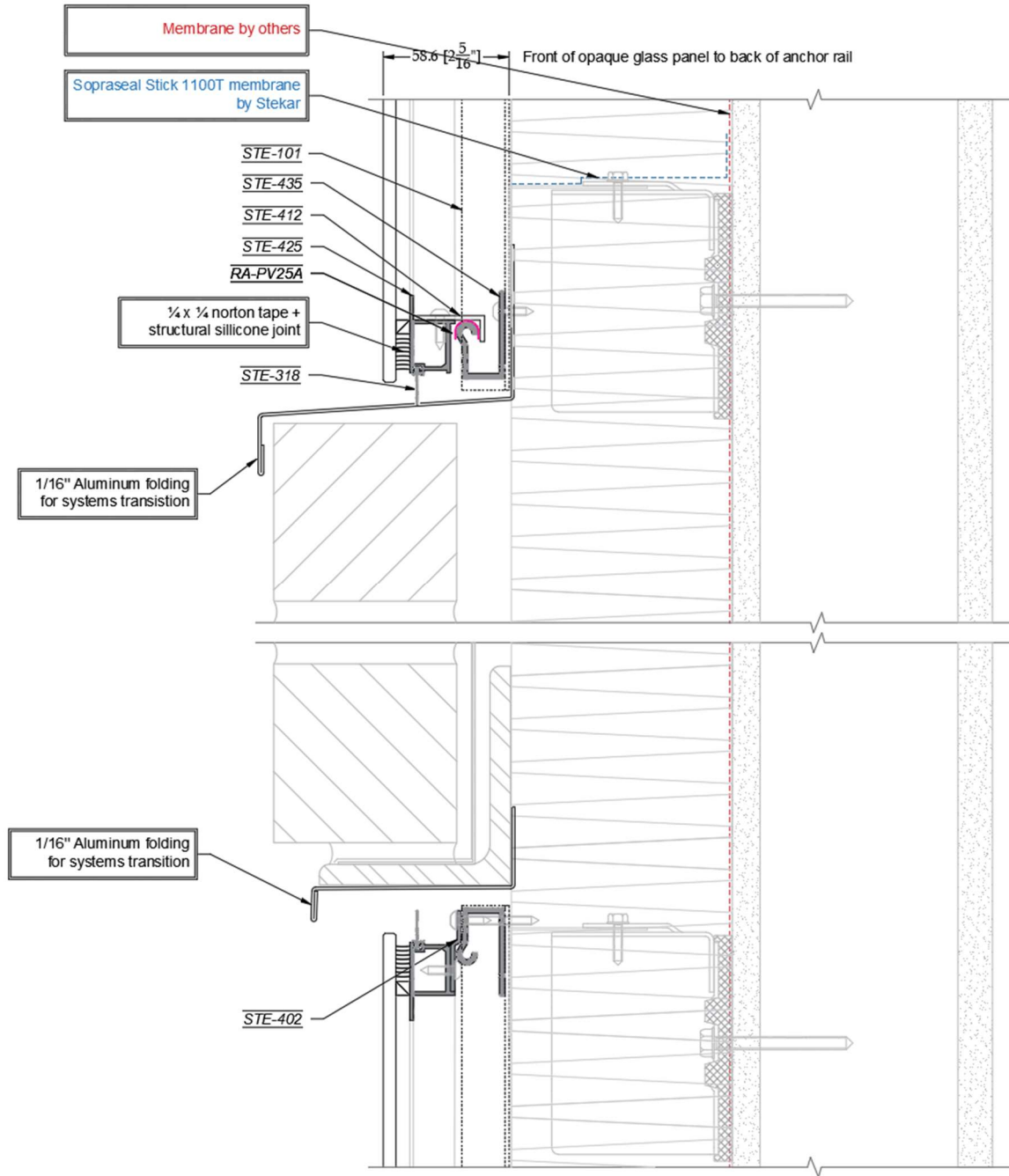



STEKAR

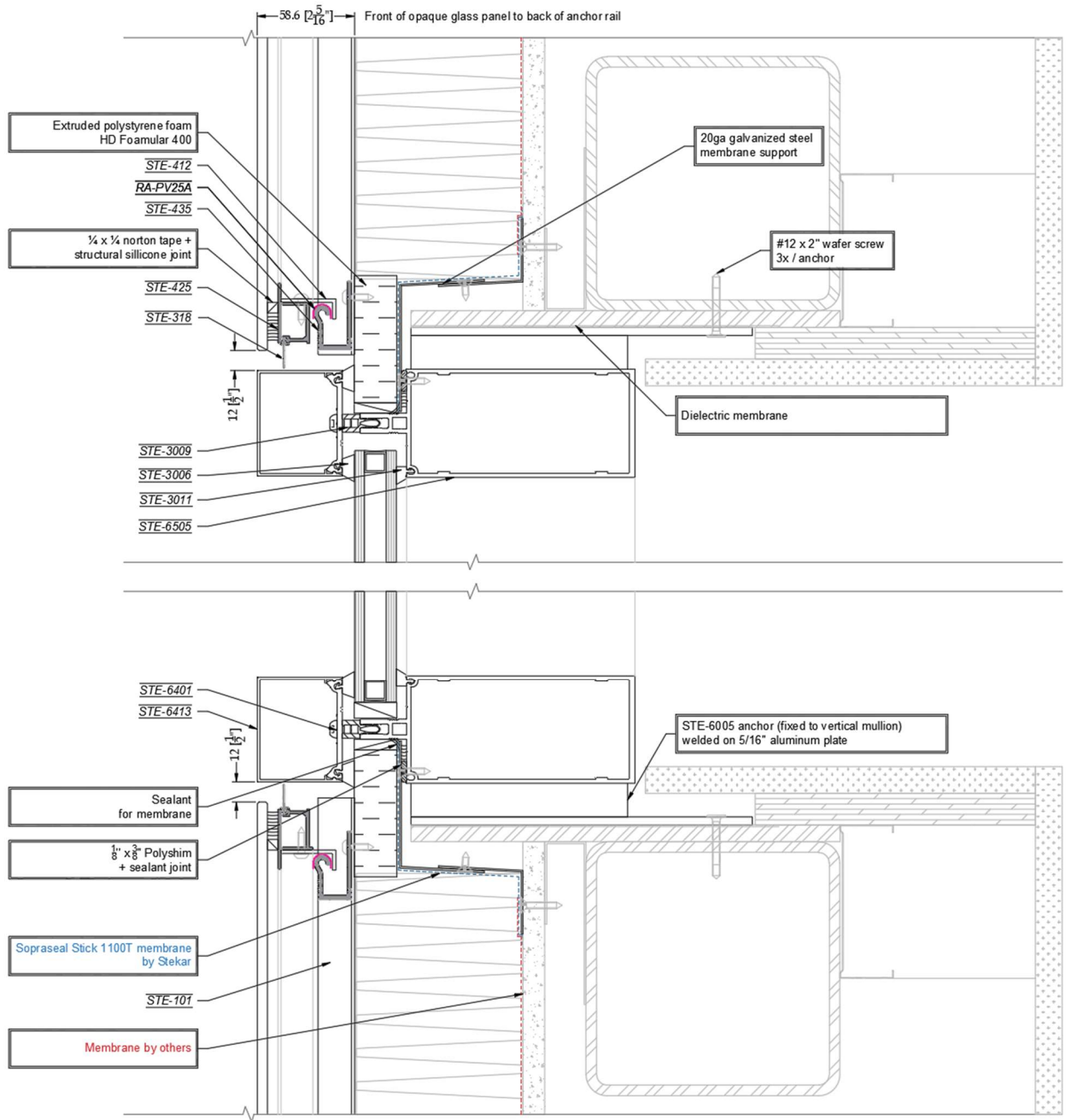



STEKAR

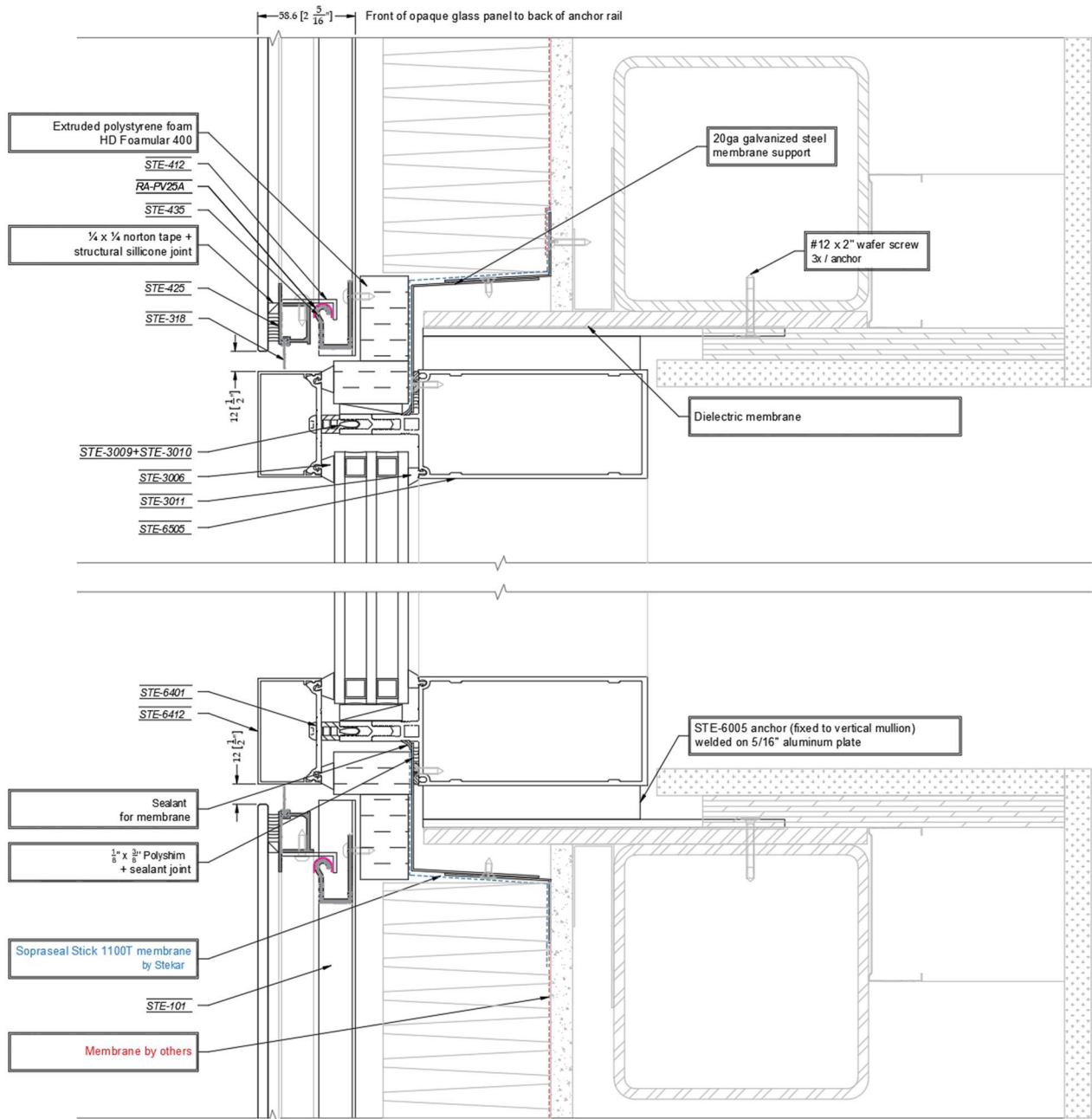

Sectional view

Opaque glass panels vs triple glass curtain wall

DC19

22 | Page



STEKAR



STEKAR

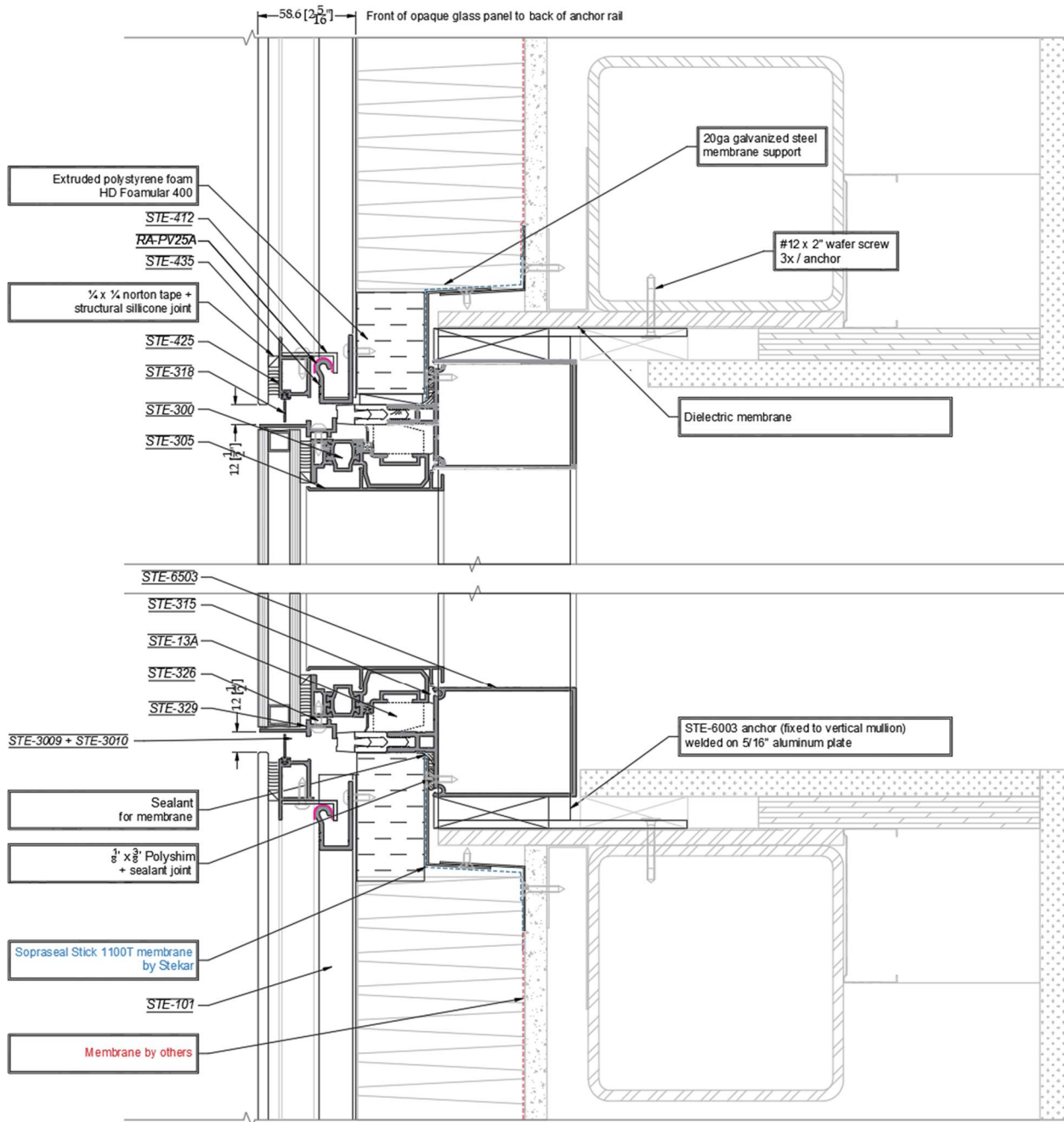

Sectional view

SM160 window vs opaque glass panels on steel

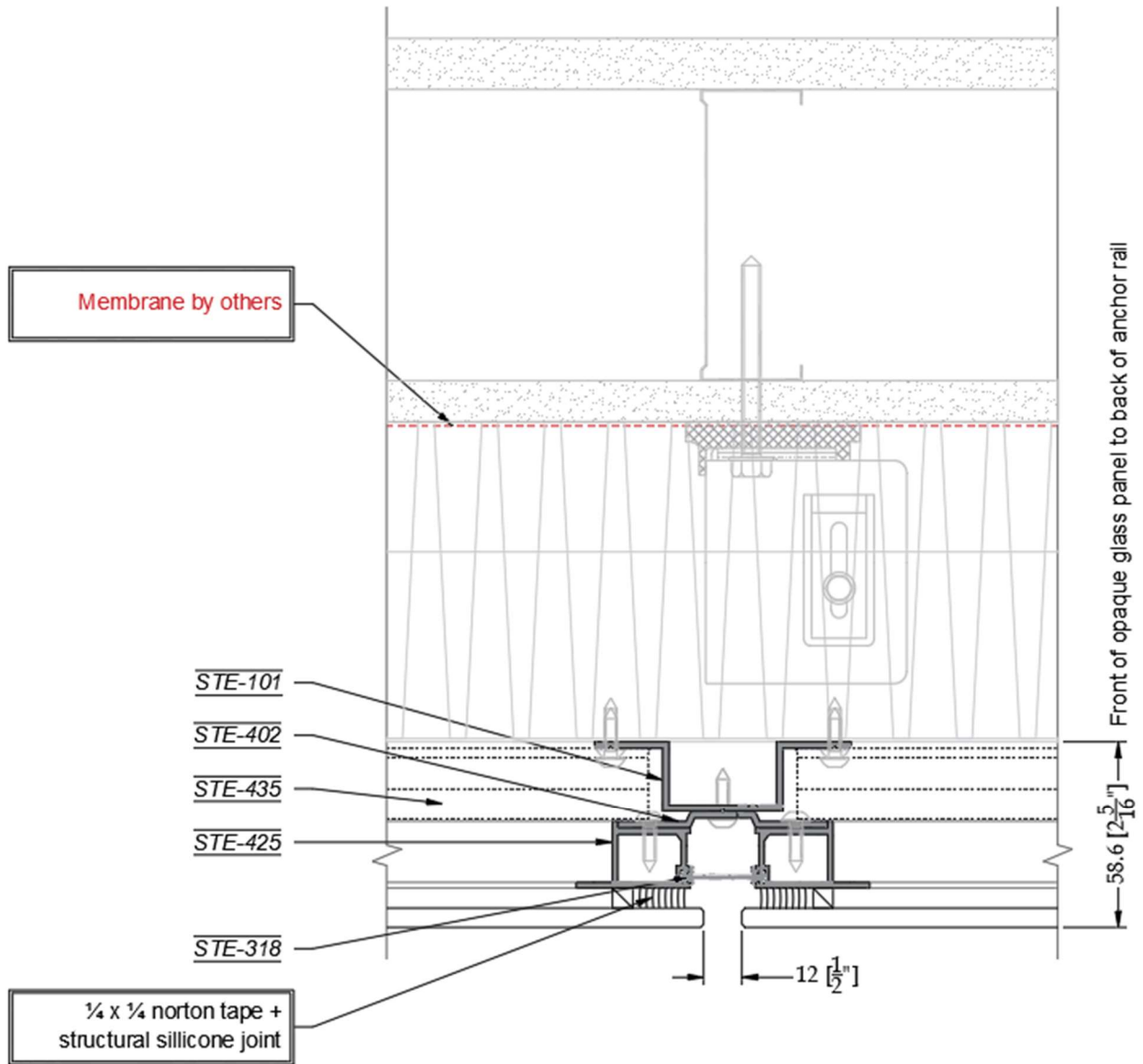



STEKAR

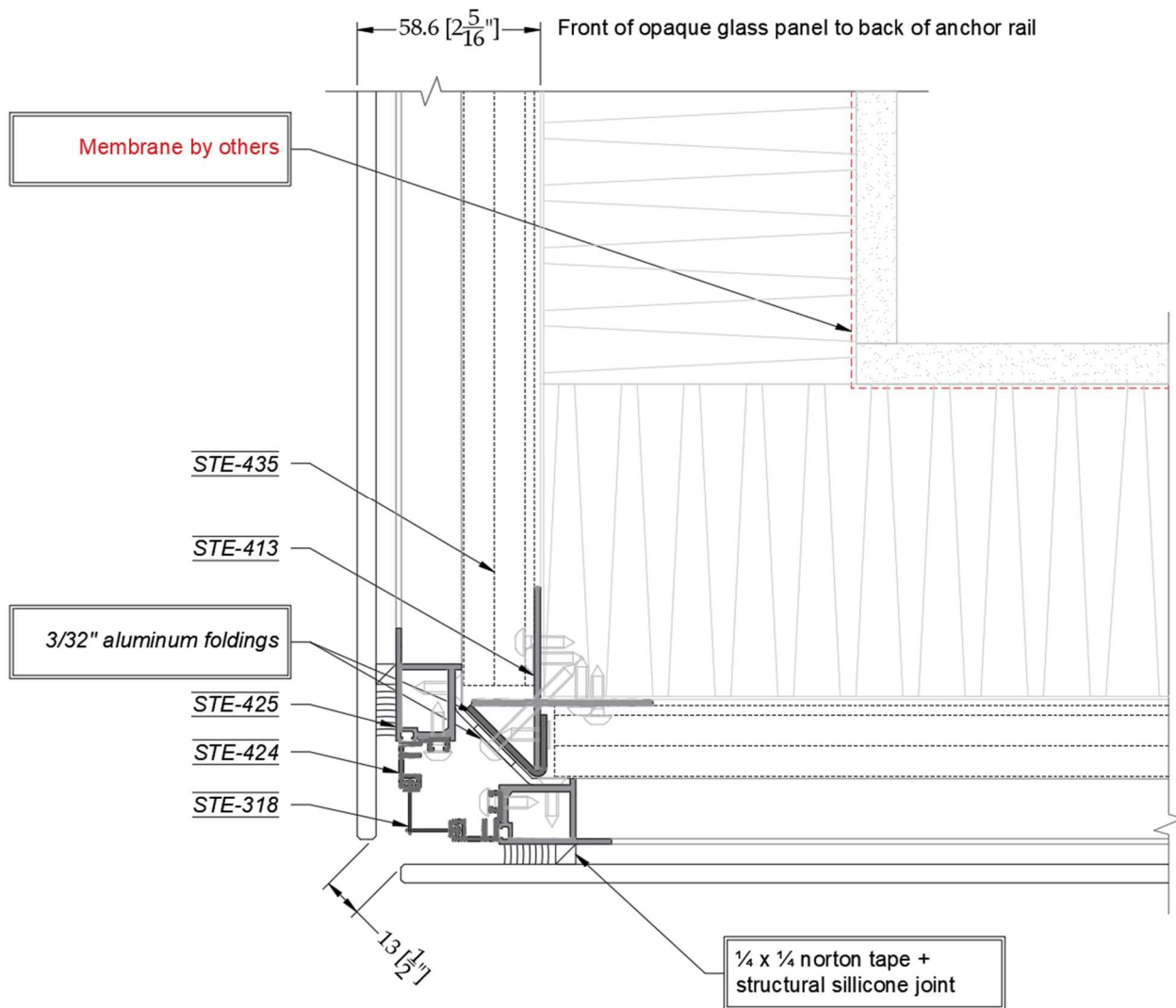



STEKAR

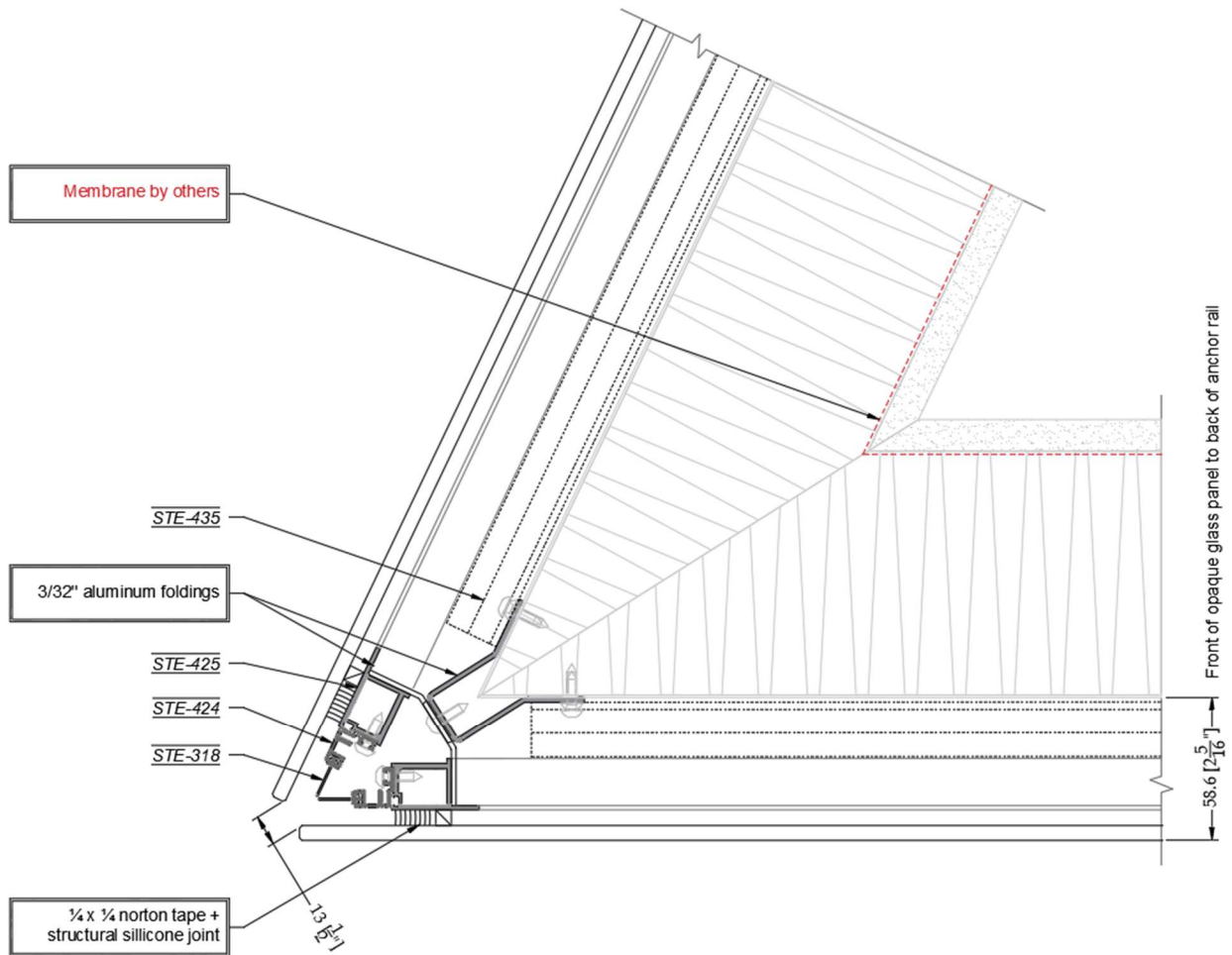

Plan view

DP03

Opaque glass panel vs opaque glass panel ; < 90° corner

27 | Page

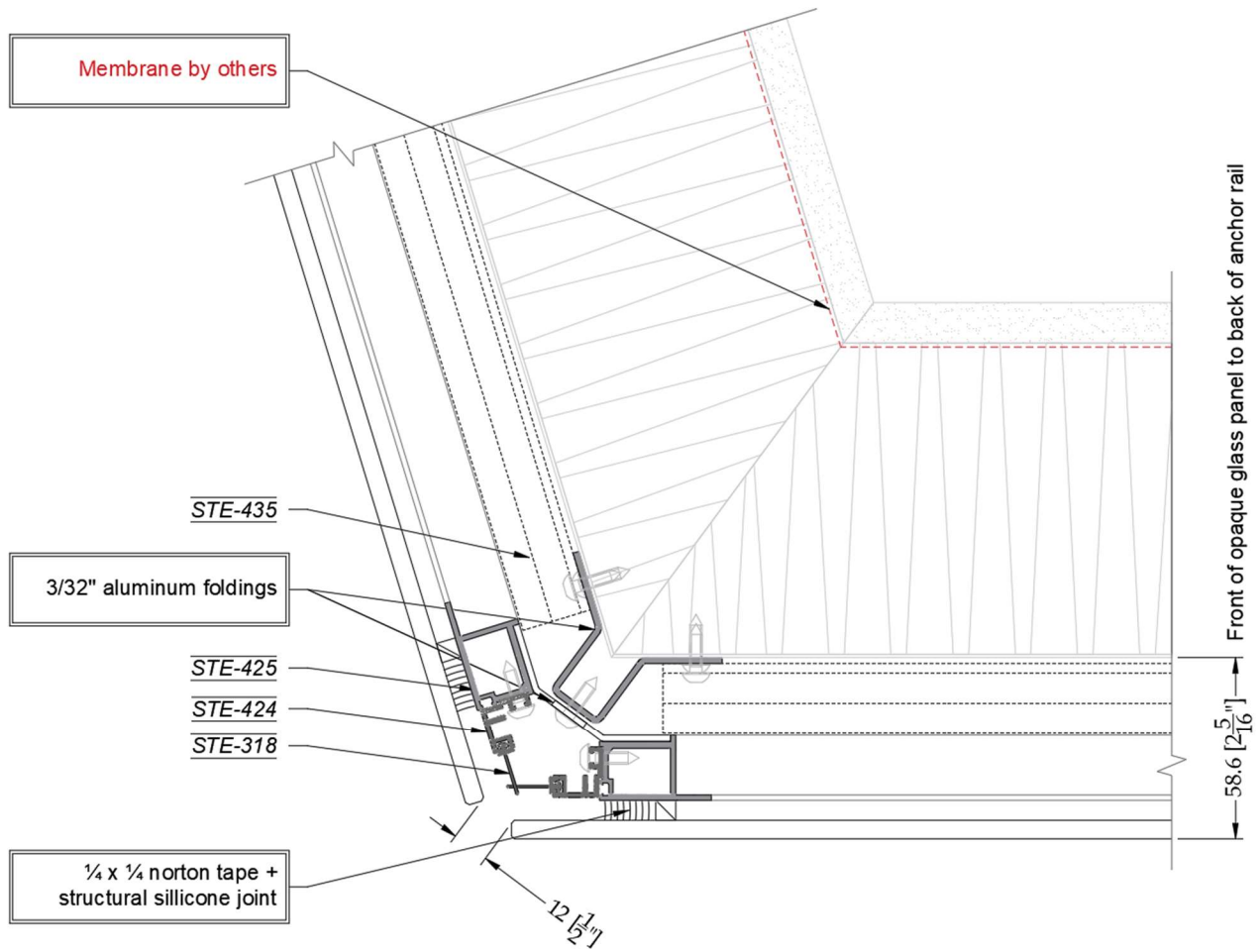



STEKAR

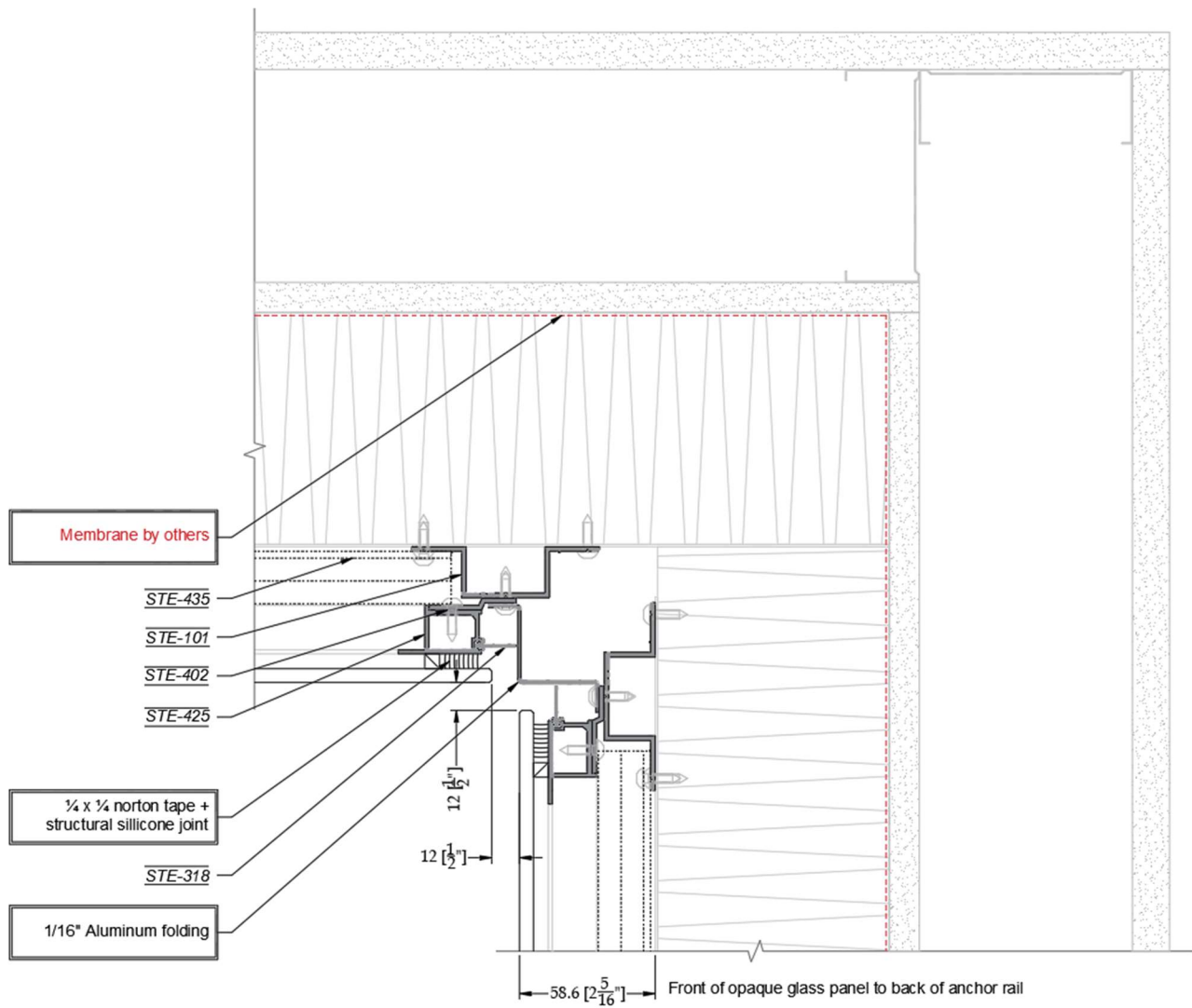



STEKAR

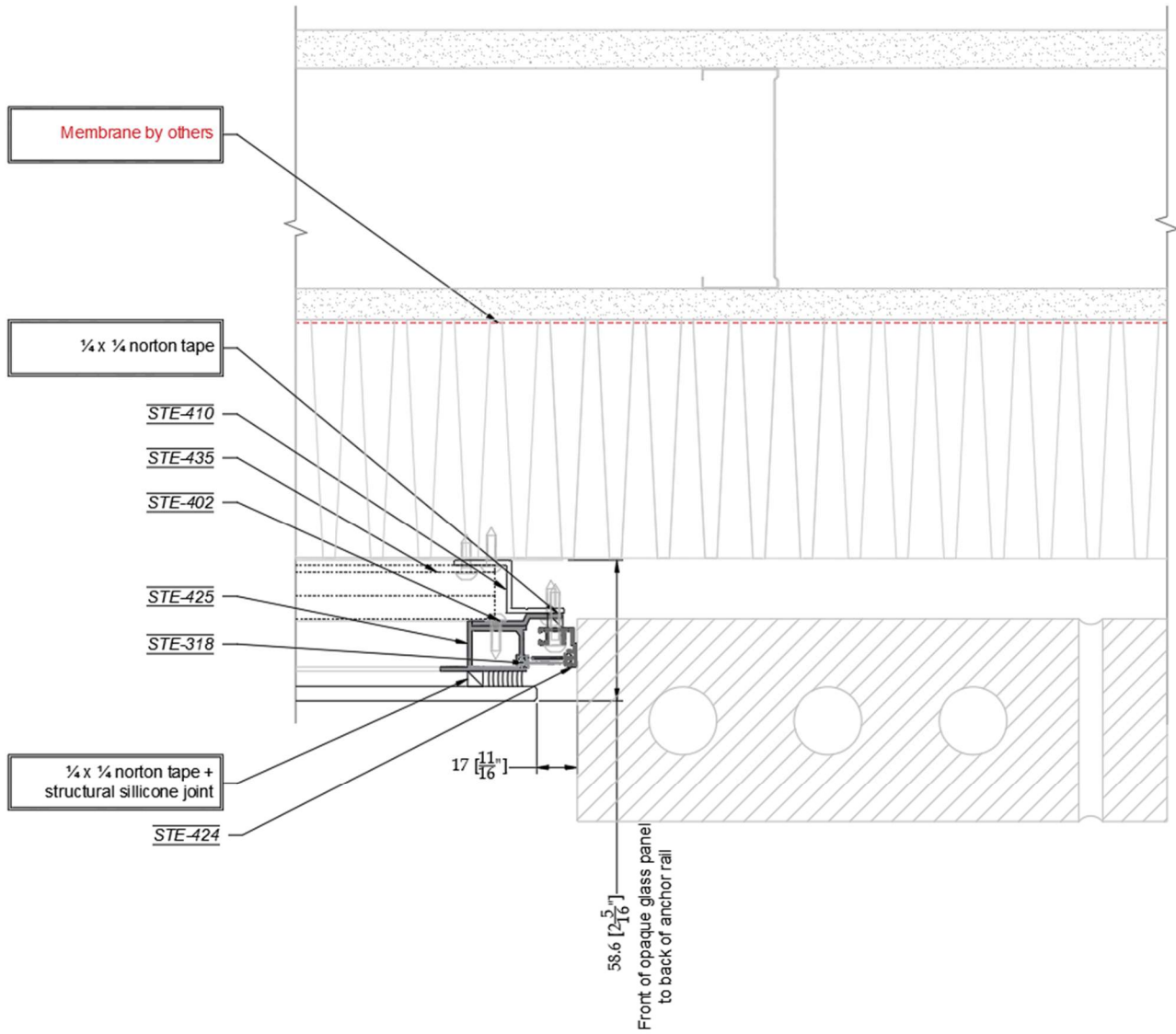



STEKAR

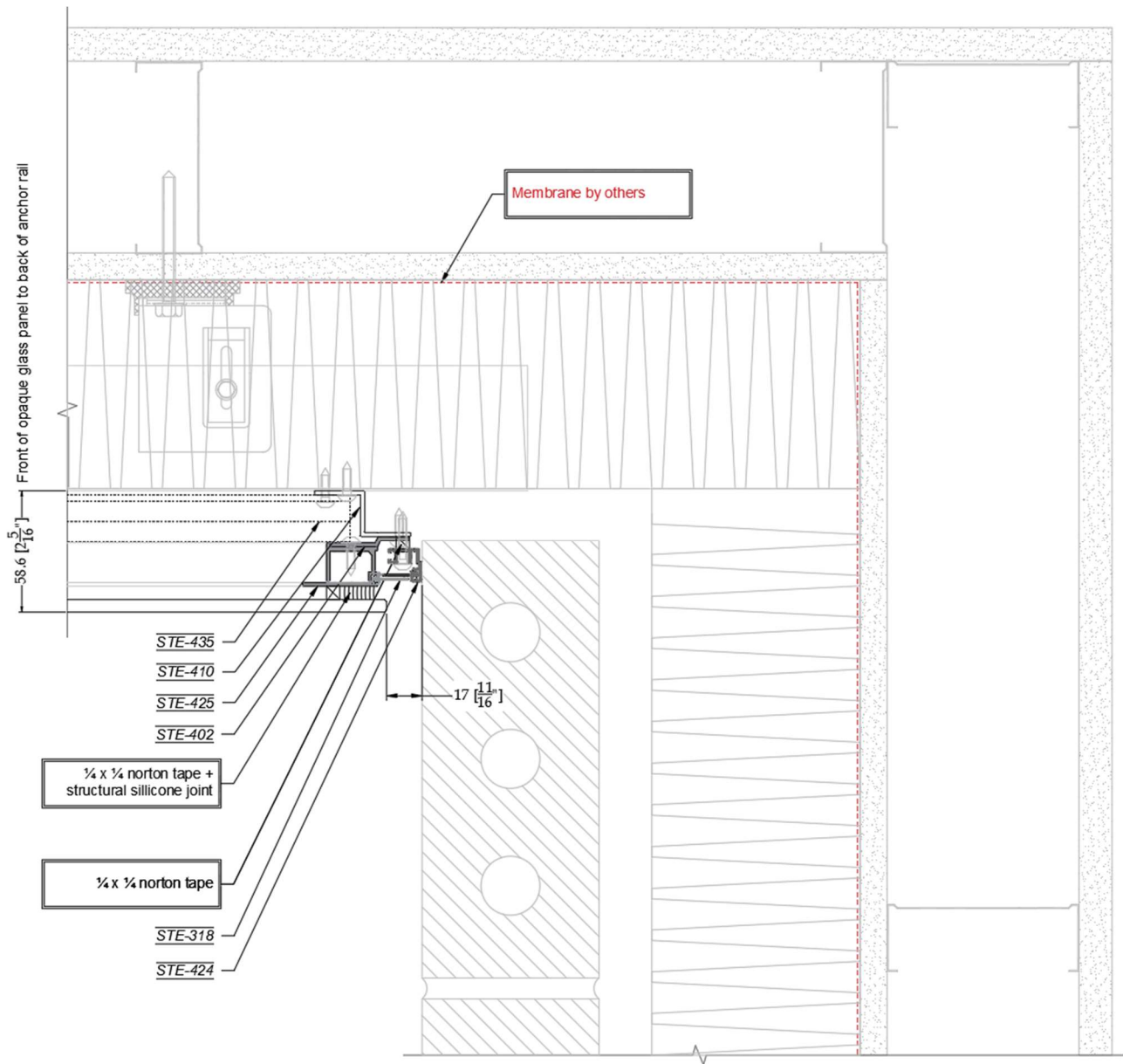



STEKAR

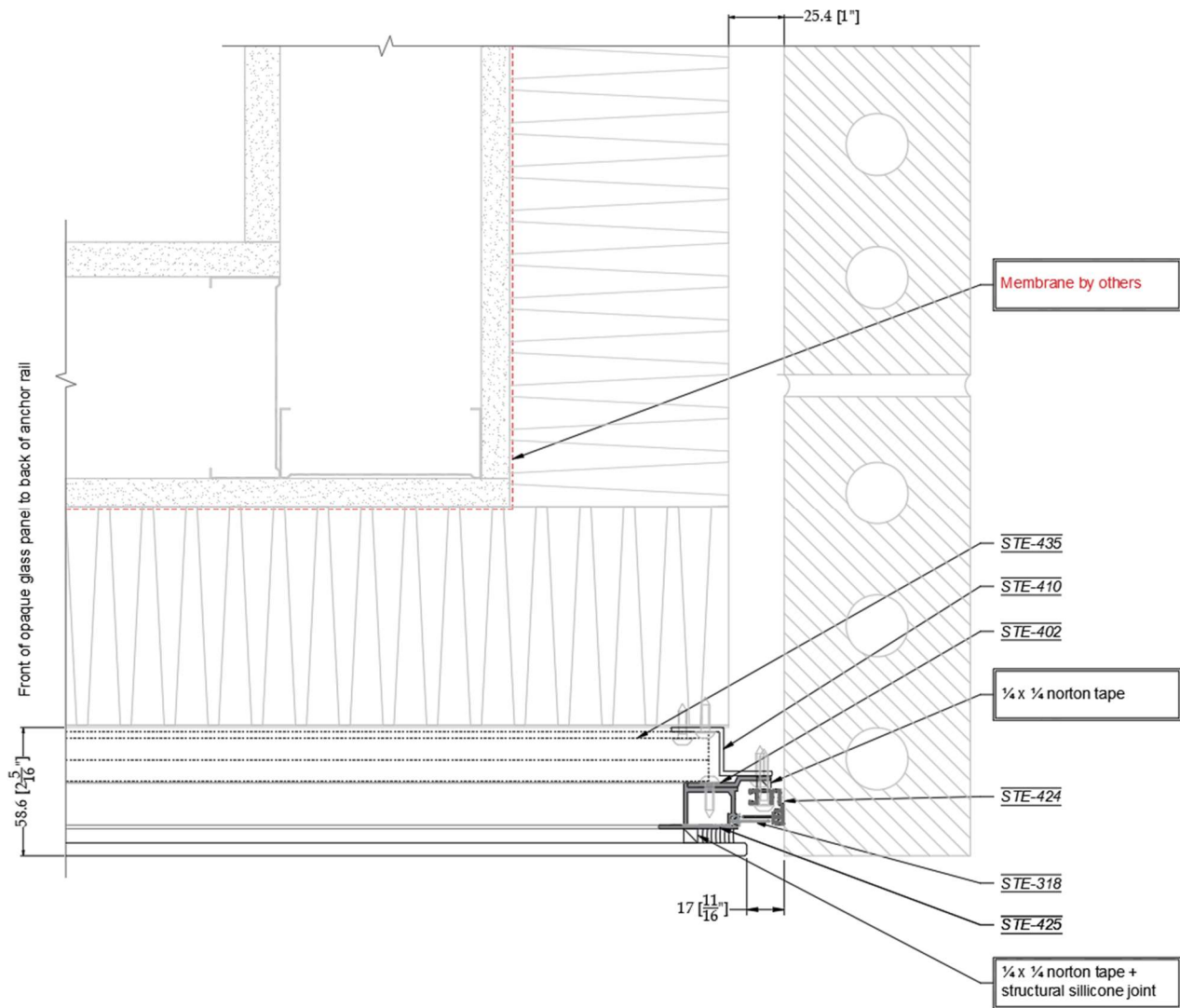



STEKAR

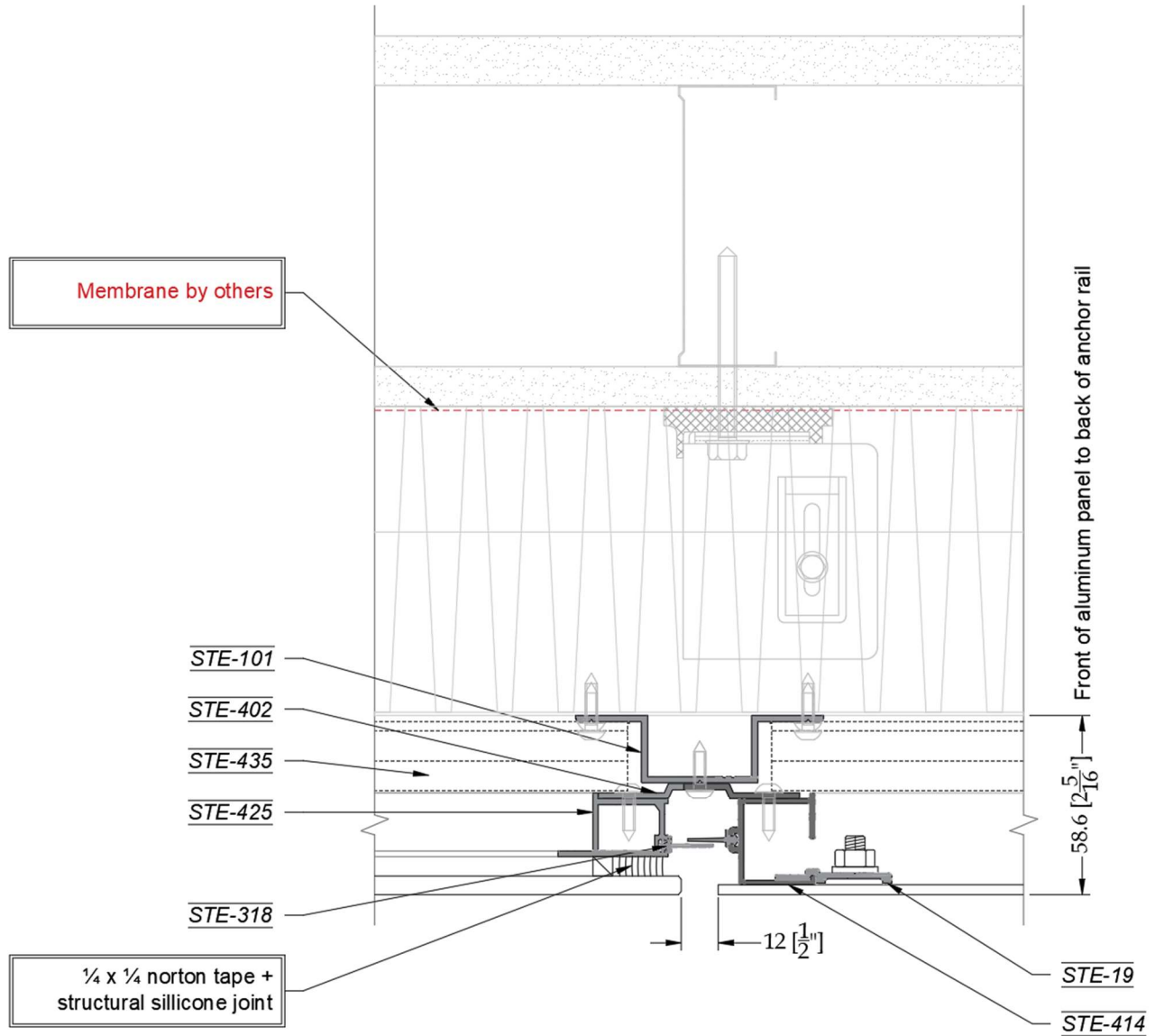



STEKAR

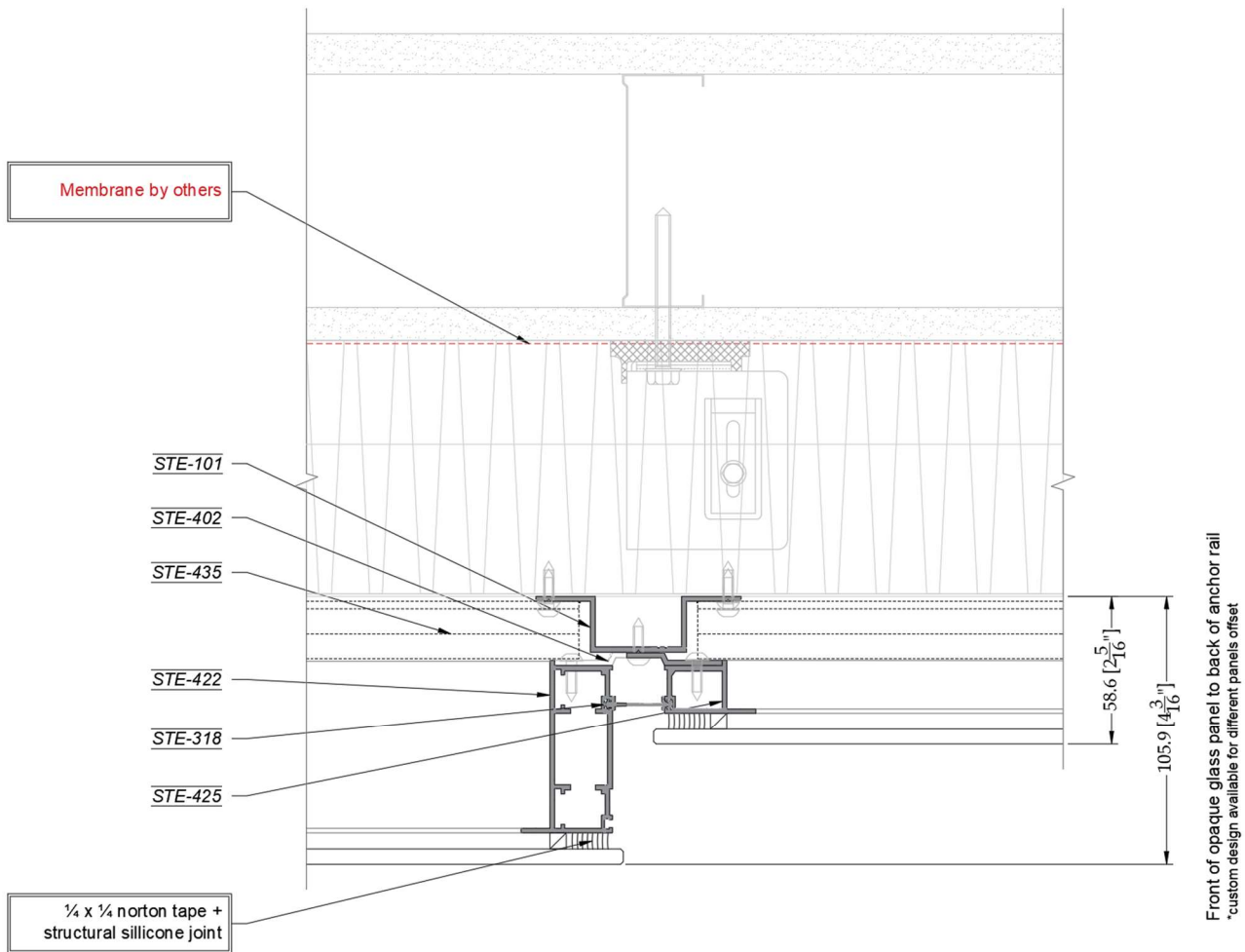



STEKAR

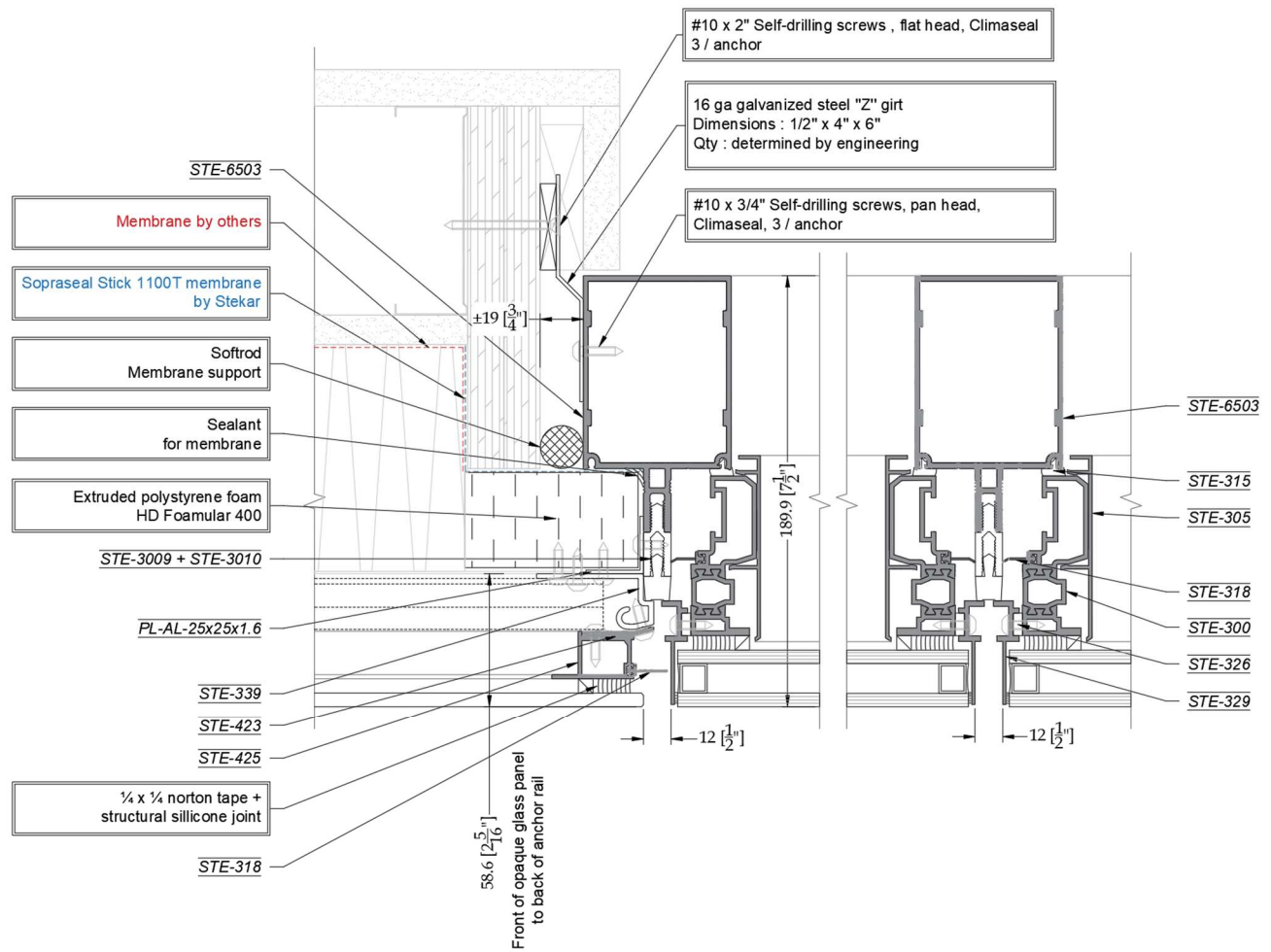



STEKAR

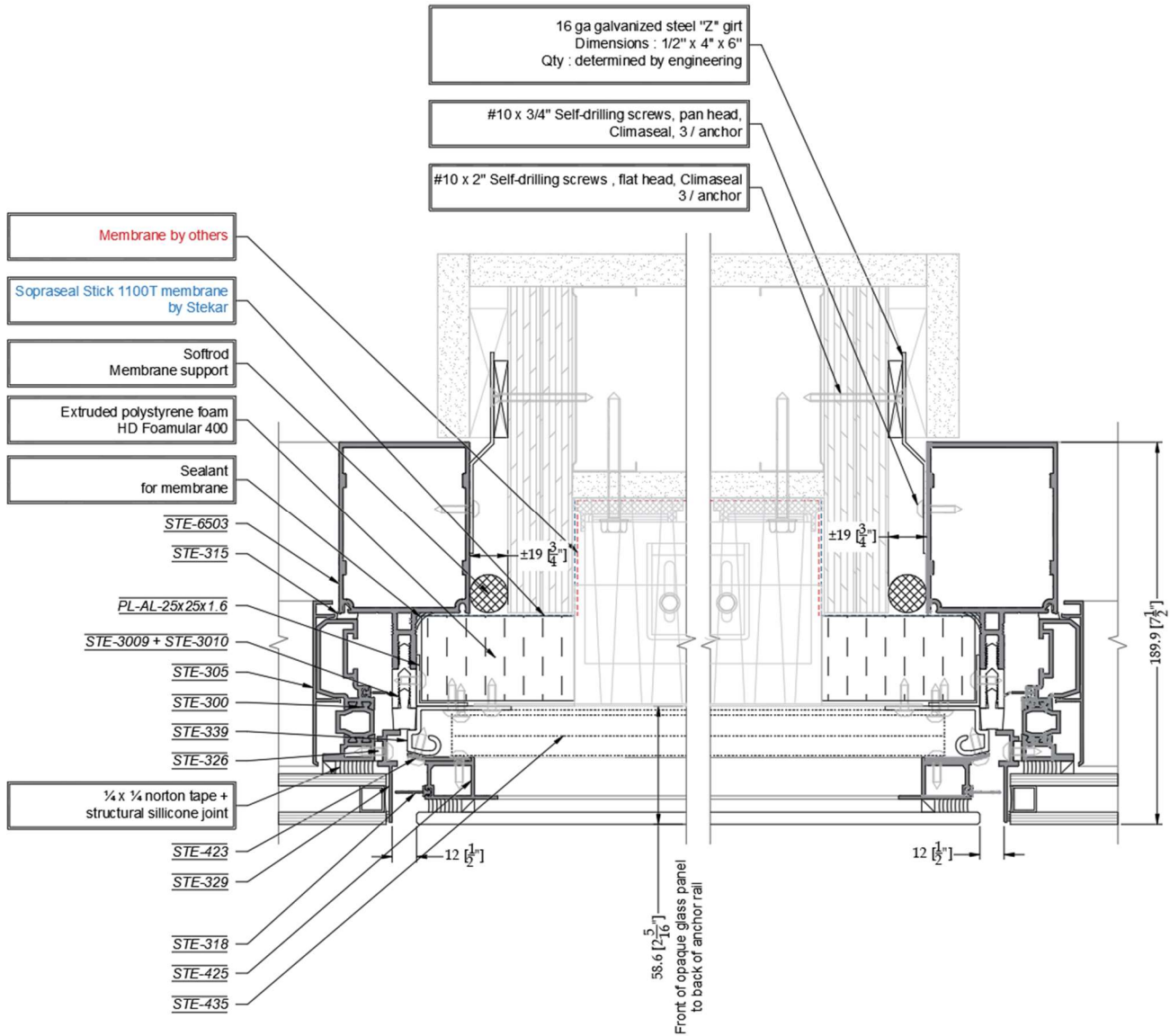



STEKAR

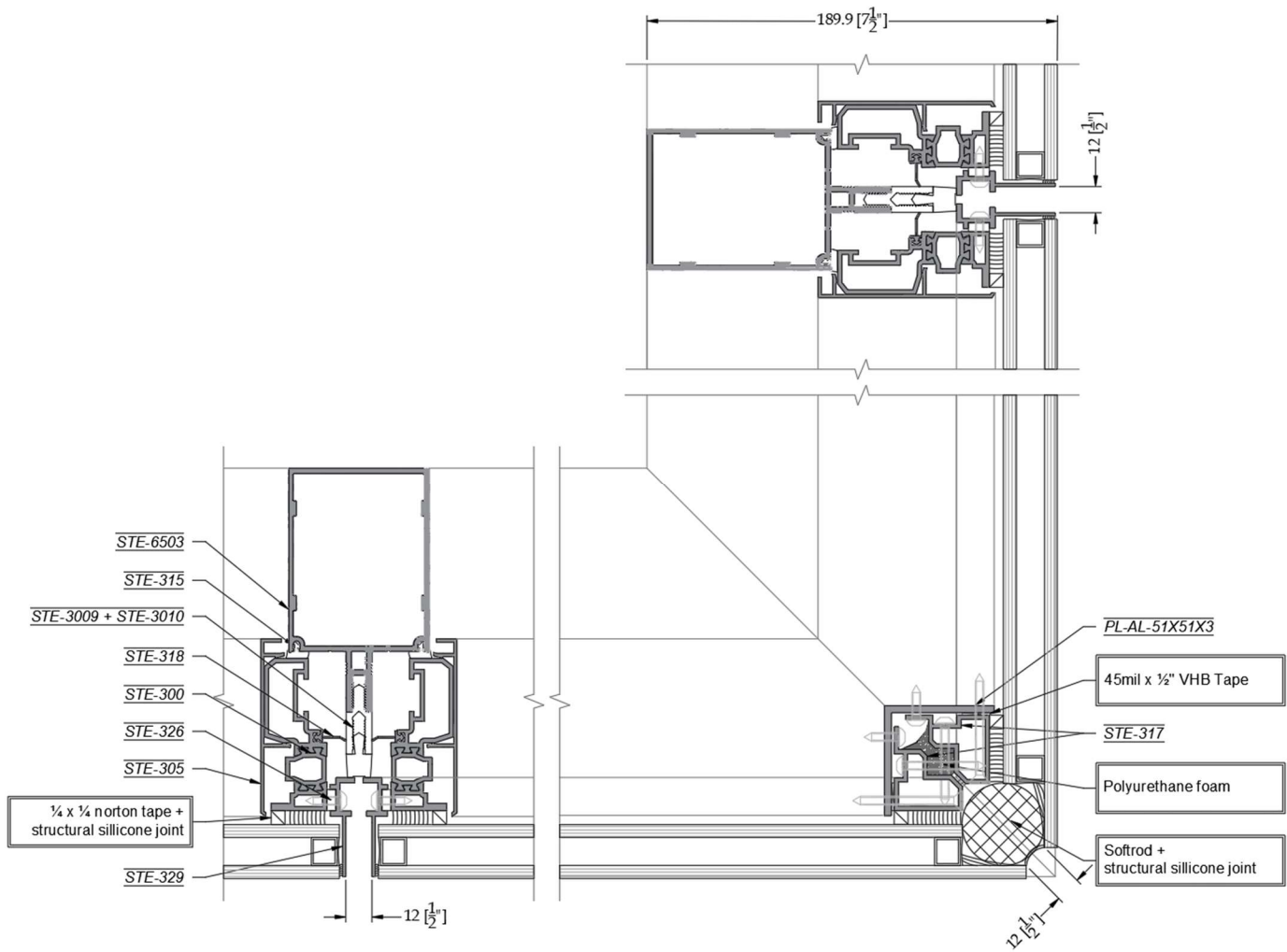



STEKAR

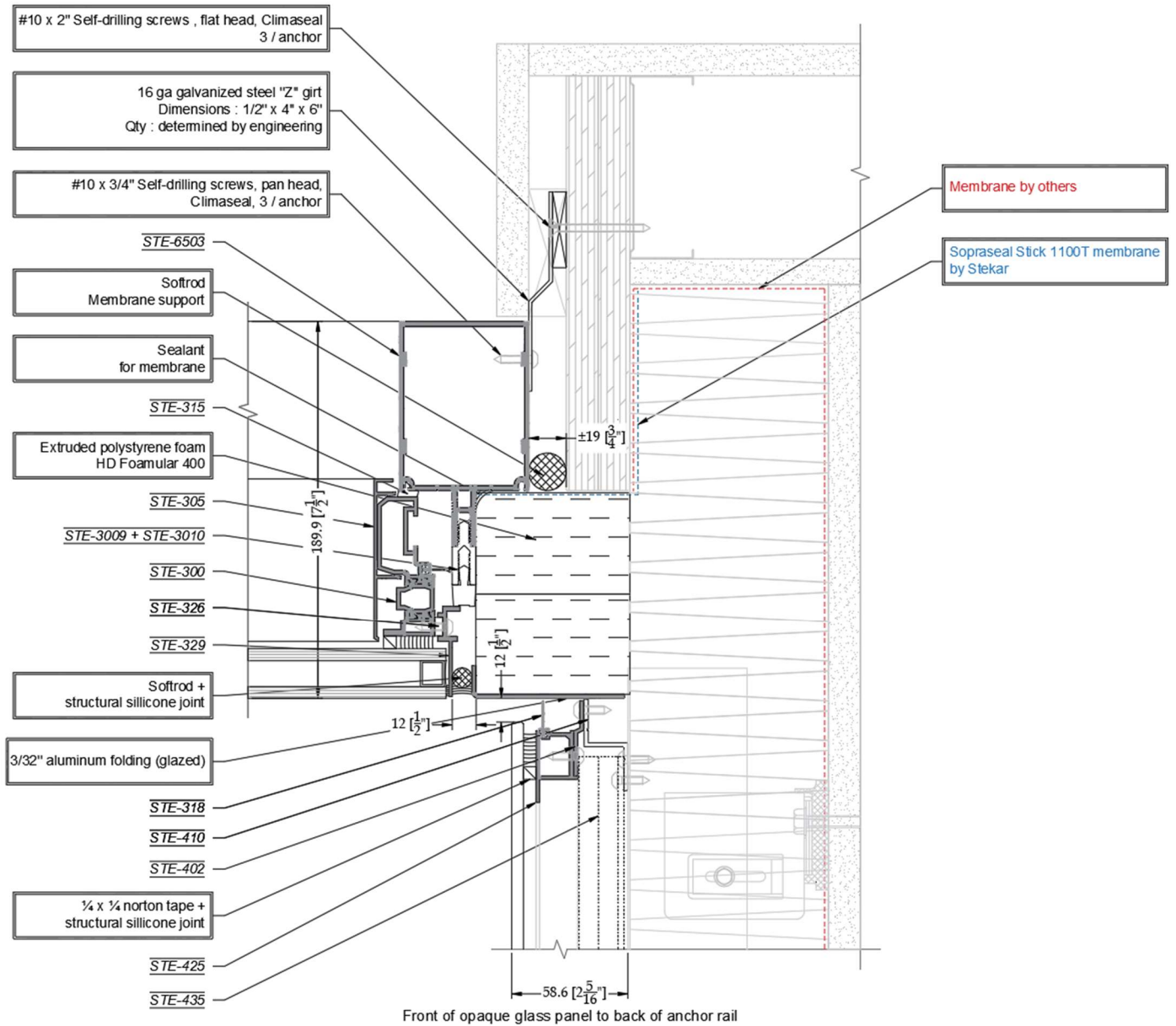



STEKAR

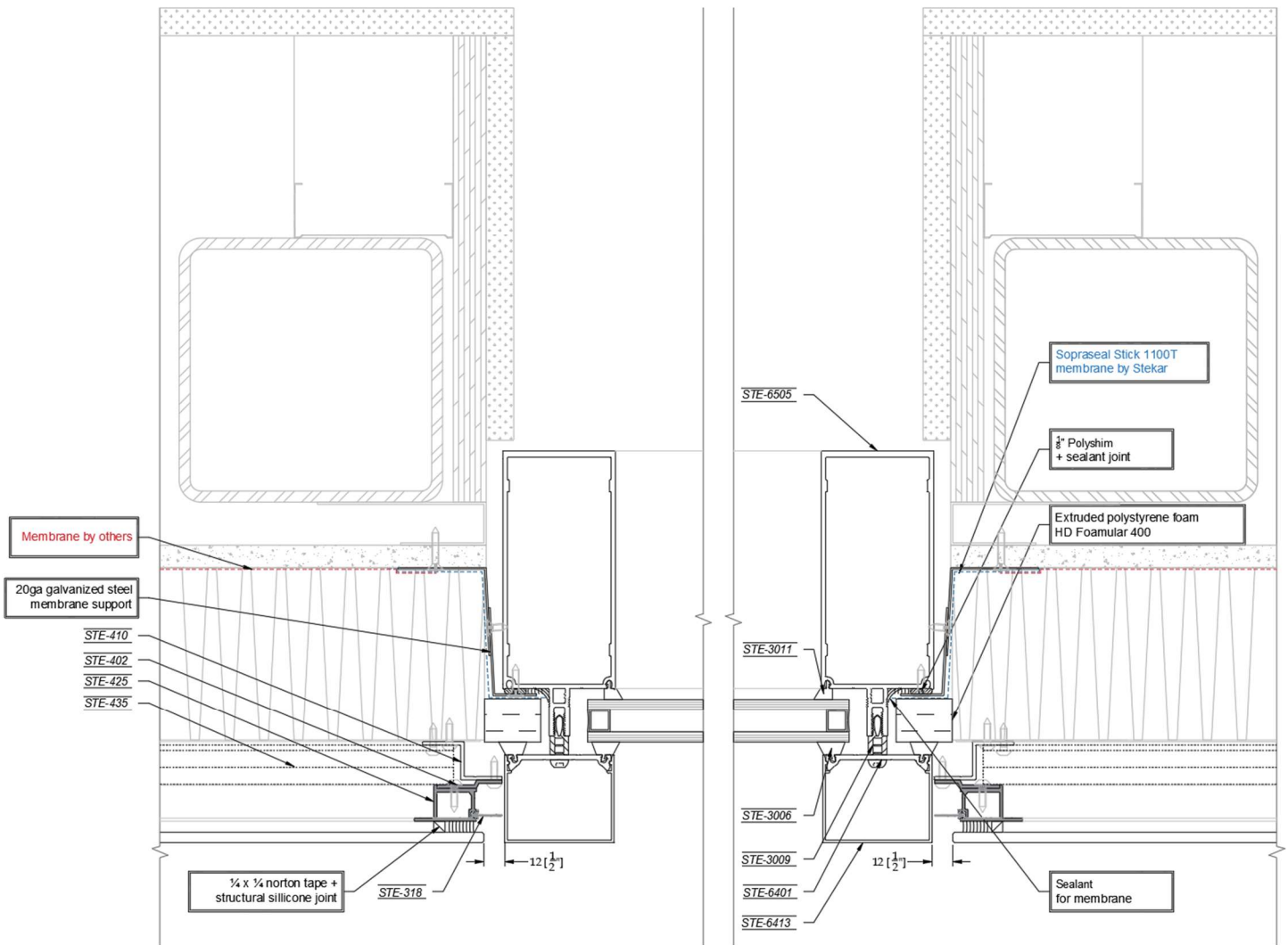

Plan view

Opaque glass panel vs curtain wall



STEKAR

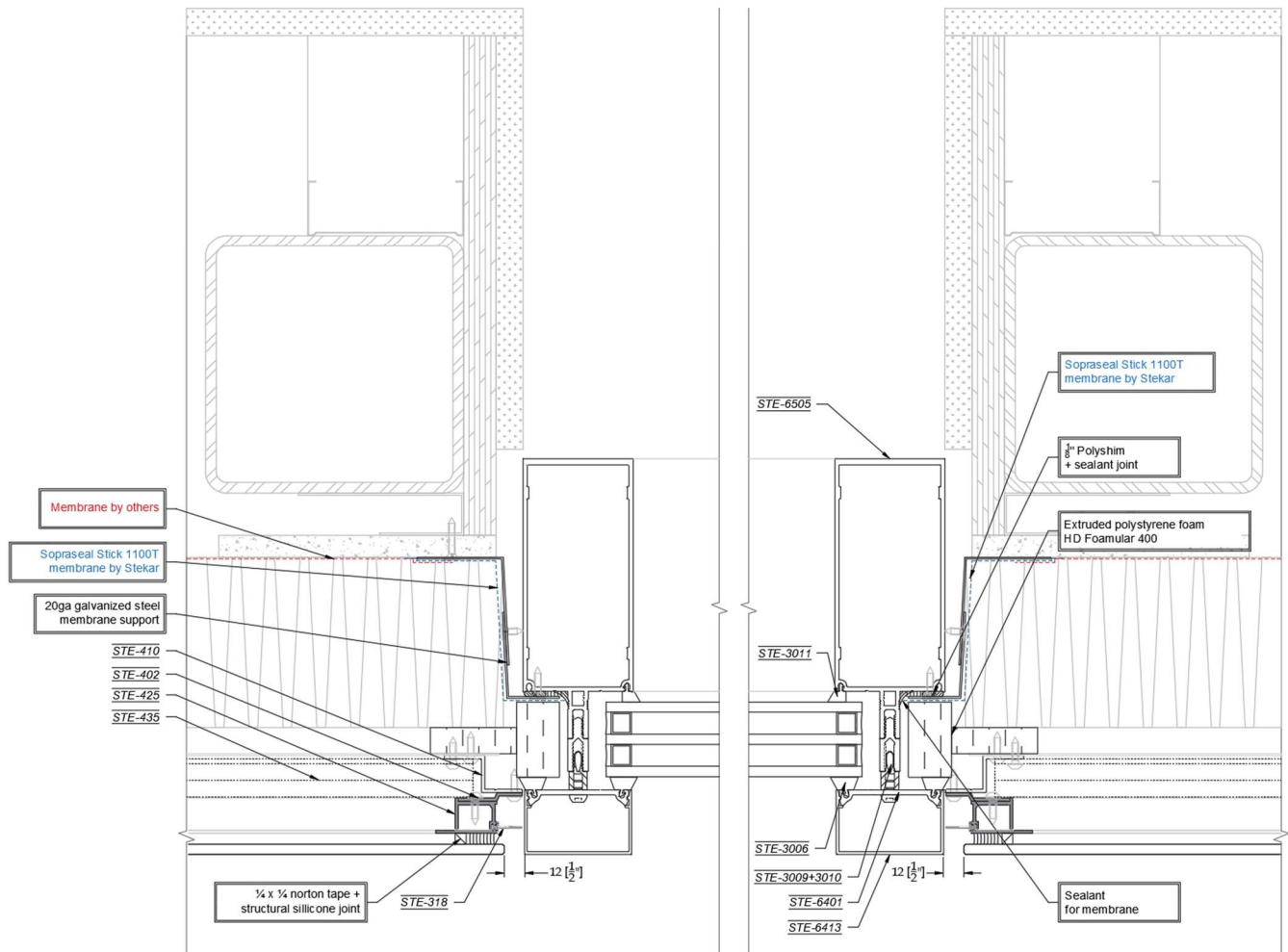

Plan view

Opaque glass panel vs triple glass curtain wall



668, 5^e Avenue
Beauceville QC G5X 1L6

P 418-774-2424
F 418-774-2425
FREE : 1-877-317-8355

SALES

ventes@stekar.com